

汇世界阀门之精华
Collect essence of world valve

创国际品牌埃姆基
Create an international brand AMG

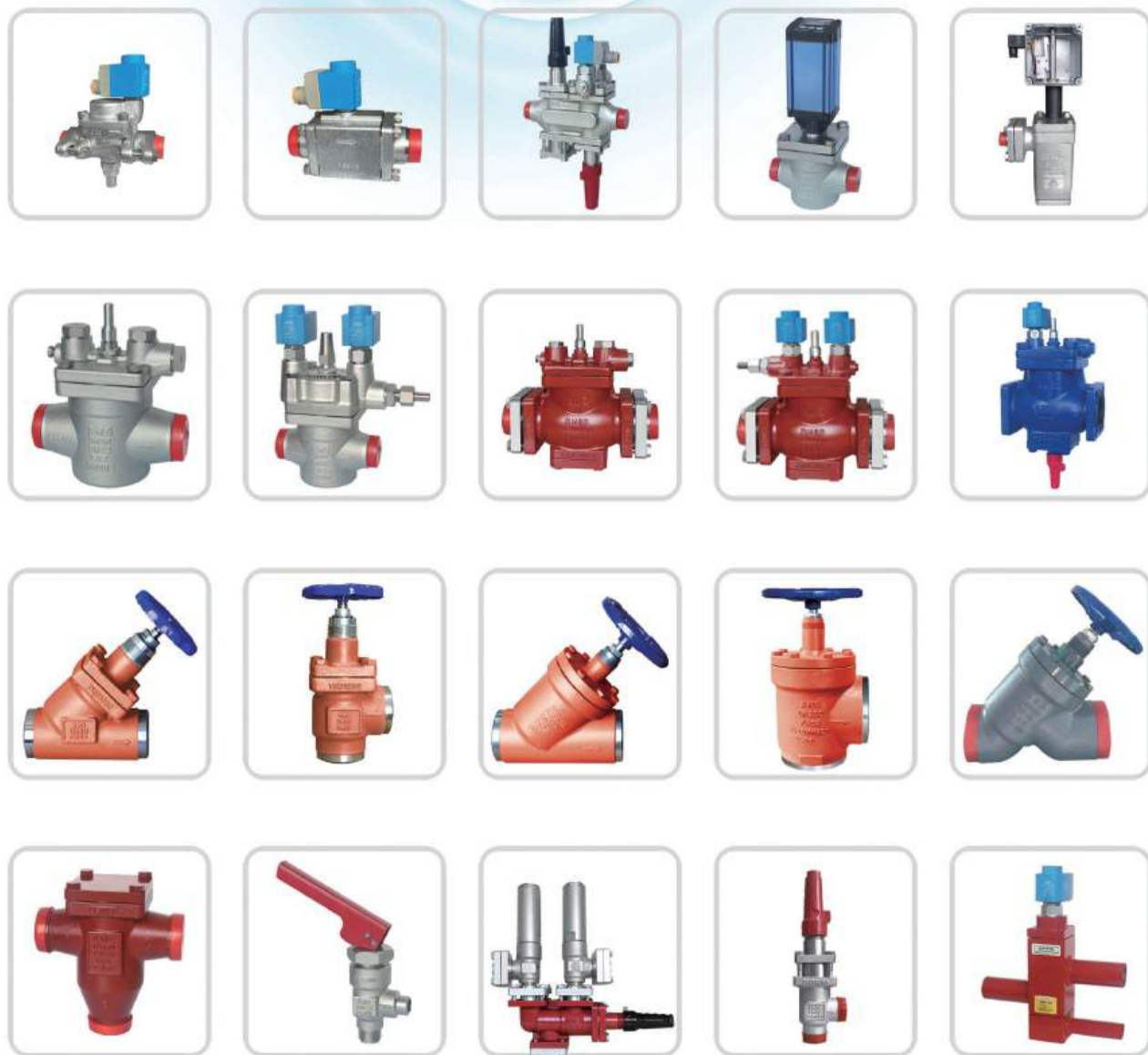

Brief introduction	4
1. Control Valve	
1.1 Main valve AICS3	5
1.2 Main valve AM	6
1.3 Motor valve AICM	7
1.4 Actuator AICAD	8
1.5 Solenoid valves AICF15/20-2-121	9
1.6 Combination valve AICF	10
2. Pilot Valve	
2.1 ACVP-L	12
2.2 ACVP-H & ACVP-X	13
2.3 ACVPP	14
2.4 ACVC	15
2.5 AEVM-NC & AEVM-NO	16
3. Solenoid Valve and Filter PN52	
3.1 AEVRA and AFA	17
3.2 AICLX	18
3.3 AMLX	19
4. Float Level Switch AKS38	20
5. Relief Valve FOV	21
6. Oil Temperature Regulating Valve ROV	22
7. Quick Drain Valve AQDV	23
8. Safety Valve and Three Way Stop Valve	
8.1 Safety valve ASFV	24
8.2 Three way stop valve ADSV1/ADSV2	25
9. Forged steel valve and Filter PN40	
9.1 Forged steel stop valve RYV/RVT	26
9.2 Forged steel regulating valve RRY/RRT	27
9.3 Forged steel stop check valve VCY/VCT	28
9.4 Forged steel check valve RCY/RCT	29
9.5 Forged steel filter FIAY/FIAT	30

10.Cast Steel Valve and Welded Steel Valve	
10.1 Cast steel stop valve RVY-ZG/RVT-ZG	31
10.2 Welded stop valve RVY/RVT	32
10.3 Cast steel stop check valve VCY-ZG/VCT-ZG	33
10.4 Welded stop check valve VCY/VCT	34
10.5 Cast steel check valve RCY/T-ZG , Filter FIAY/T-ZG	35
10.6 Welded check valve RCY/T , Filter FIAY/T	36
10.7 TDZ Filter	37
11.Forged Steel Valve and Filter PN52	
11.1 CO ₂ stop valve SVY/SVT	38
11.2 CO ₂ control valve REY/RET	39
11.3 CO ₂ check valve CHY/CHT	40
11.4 CO ₂ stop check valve SCY/SCT	41
11.5 CO ₂ filter FIY/FIT	42
12.Stainless Steel Valve	
12.1 Stainless steel stop valve RVY-SS/RVT-SS	43
12.2 Stainless steel control valve RRY-SS/RRT-SS	44
12.3 Stainless steel check valve RCY-SS/RCT-SS	45
12.4 Stainless steel stop check valve VCY-SS/VCT-SS	46
12.5 Stainless steel filter FIA-SS-Y/FIA-SS-T	47
13.ANRVA / RCH Check Valve	48
14.Small Size Stop Valve	49
15.Sight Glass	
15.1 LLG-A Sight glass	53
15.2 SG-A Sight glass	54
16.Typical Applications	55
17.Certifications and Qualifications	61

AMG is a professional manufacturer of industrial refrigeration valves. AMG covers an area of 10,000 m² and has a construction area of 6,000 m². New factory will be finishing construction in June of 2026, which covers an area of 23000m² and has a construction area of 15000 m². AMG has 150 staffs, include 15 professional engineers.

Industrial refrigeration valve in AMG series are featured by good-looking and artistic appearance, advanced and unique structure, light and flexible operation, excellent sealing performance, zero leakage, high reliability and long service life. They are widely used in refrigerated-storage and freezing systems in the industries of cooling, refrigeration and air-conditioning as well as the industries of food, beverage, bear, pharmaceutical, ship-building, gas, chemical, petroleum, etc.

AMG valve is the top brand of refrigeration valves in China. We set the Chinese standard “JB/T 7245-2017 Steel and iron shut off valve and lift check valve in refrigeration” with Danfoss together. AMG has certification of PED, ISO9001, ISO14001, ISO45001.

For Chinese market, AMG serves as the designated supplier for Moon Tech, Snowman Group, Binshan Group and Johnson Controls. For oversea market, AMG is not only the OEM of Parker Hannifin US and Europe, as well as Russia RIDAN, but also has many oversea distributors such as Vietnam, Iran, Spain, New Zealand, Colombia, Argentina etc.

A high-performance refrigeration system is dependable on high quality components. The application of AMG series Industrial refrigeration valve with high quality and reasonable price will offer you a complete alternative for expensive imported valves while adding luster to your products.

Partner



Technical parameters

Nominal pressure: 5.2MPa Applicable temperature: -45°C ~ +120°C
 Test pressure: 7.8MPa Applicable medium: Ammonia, Freon, CO₂, etc.

Characteristics

- AICS pressure control valves (further-valve) are pilot operated valves for regulating pressure, temperature and ON/OFF function in refrigeration systems. Valves are designed for low and high-pressure refrigerants.
- Valves can be used on the high and low pressure sides, in wet and dry suction lines and in liquid lines without phase change (i.e. where no expansion takes place in the valve).
- The function of valves is dependent on the pilot pressure applied from either a pilot valve or external pilot pressure source.
- Two of the three pilot pressure connections (S1 and S2) are connected in series whilst the third (P) is connected in parallel to S1 and S2. This allows different combinations of pilot valves to be used, thus providing numerous variations in control functions.
- The AICS valve will be fully closed if the pilot valve in P is fully closed and at least one of the valves in S1 or S2 is fully closed at the same time. The relation between the pilot valves in ports S1, S2 and P is shown in the table.
- Valves is not fitted with three pilot valves, the unused port(s) must be sealed with a blanking plug.
- Plug type "A"- does not block the internal channels in the valve, i.e. the port will be open.
- Plug type "B"- blocks the internal channels of the valve, i.e. the port will be completely closed.

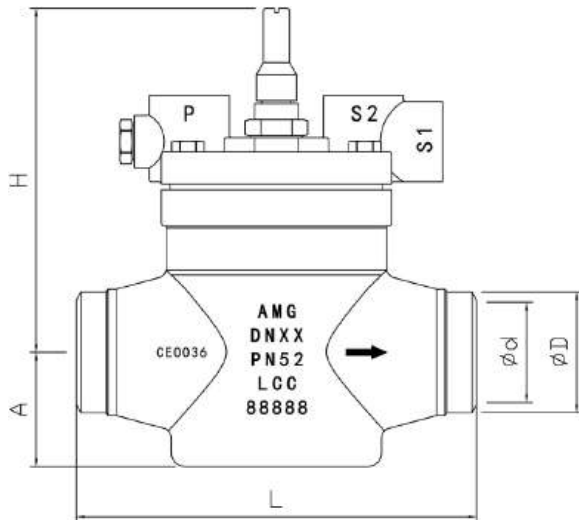

Ports			AICS3
S1	S2	P	
open	open	closed	open
open	open	open	open
open	closed	closed	closed
open	closed	open	open
closed	open	closed	closed
closed	open	open	open
closed	closed	closed	closed
closed	closed	open	open

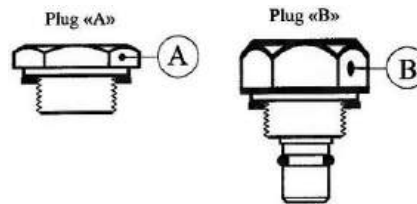

Name	Type	Size(mm)					kv	Cv
		φD	φd	A	H	L		
AICS3 Main Valves Type	AICS3 20	27	20	35	140	135	8	9.3
	AICS3 25	34	25	35	140	135	11.5	11.3
	AICS3 32	42	32	49	150	160	17	20
	AICS3 40	48	40	49	150	160	27	31
	AICS3 50	60	50	57	170	200	44	51
	AICS3 65	76	65	65	195	230	70	81
	AICS3 80	89	80	65	195	230	85	98
	AICS3 100	108	100	105	380	300	142	165
	AICS3 125	133	121	120	392	350	207	240
AICS3 150	159	146	175	433	445	354	410	

Technical parameters

Nominal pressure: 2.8MPa Applicable temperature: $-45^{\circ}\text{C} \sim +120^{\circ}\text{C}$
 Test pressure: 4.2MPa Applicable medium: Ammonia, Freon, CO_2 , etc.

Characteristics

- AM pressure control valves (further - valve) are pilot operated valves for regulating pressure, temperature and ON/OFF function in refrigeration systems. Valves are designed for low and high-pressure refrigerants.
- Valves can be used on the high and low pressure sides, in wet and dry suction lines and in liquid lines without phase change (i.e. where no expansion takes place in the valve).
- The function of valves is dependent on the pilot pressure applied from either a pilot valve or external pilot pressure source.
- Two of the three pilot pressure connections (S1 and S2) are connected in series whilst the third (P) is connected in parallel to S1 and S2. This allows different combinations of pilot valves to be used, thus providing numerous variations in control functions.
- The PM valve will be fully closed if the pilot valve in P is fully closed and at least one of the valves in S1 or S2 is fully closed at the same time. The relation between the pilot valves in ports S1, S2 and P is shown in the table.
- Valves are not fitted with three pilot valves, the unused port(s) must be sealed with a blanking plug.
- Plug type "A" - does not block the internal channels in the valve, i.e. the port will be open
- Plug type "B" - blocks the internal channels of the valve, i.e. the port will be completely closed.

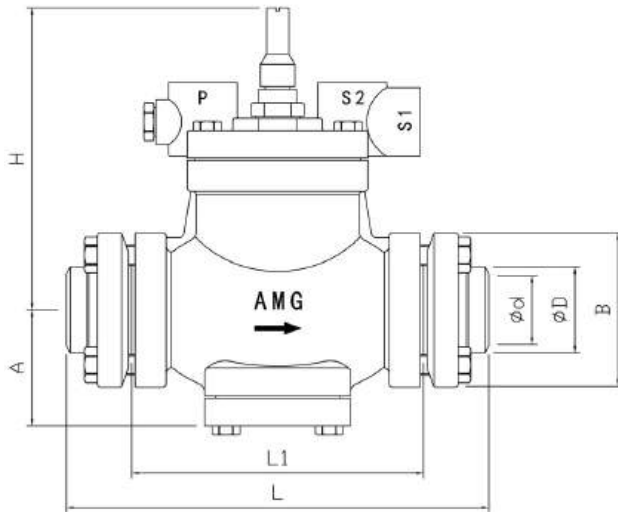

Ports			AM3
S1	S2	P	
open	open	closed	open
open	open	open	open
open	closed	closed	closed
open	closed	open	open
closed	open	closed	closed
closed	open	open	open
closed	closed	closed	closed
closed	closed	open	open

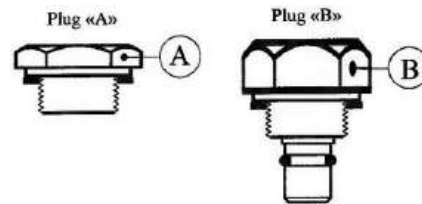

Name	Type	Size(mm)						kv	Cv
		ϕD	ϕd	A	H	L	L1		
AM Main Valves Type	AM 20	27	20	65	150	190	125	6	7
	AM 25	34	25	65	150	190	125	9	10.5
	AM 32	42	32	70	175	245	170	16	19
	AM 40	48	40	70	175	245	170	30	35
	AM 50	60	50	70	180	255	180	40	47
	AM 65	76	65	85	205	295	220	75	88
	AM 80	89	80	95	225	330	250	140	164
	AM 100	108	100	125	260	415	330	200	234
	AM 125	133	121	120	405	350	/	207	240
AM 150	159	146	150	445	445	/	354	410	

Motor Valve AICM

Technical parameters

Nominal pressure: 5.2MPa	Applicable temperature: -45°C ~ +120°C
Test pressure: 7.8MPa	Applicable medium: Ammonia, Freon, CO ₂ , etc.



Characteristics

- AICM 20-65: Suitable for all refrigerants including ammonia, carbon dioxide, and non corrosive gases/liquids. AICM 100-150: Suitable for refrigerant ammonia.
- The motor valve consists of four components: valve body, valve cover, functional module, and actuator. The valve cover and functional module are integrated in AICM 20-65.
- AICM is an motor valve directly driven by the actuator AICAD (industrial control actuator with display screen).
- The balanced design of the AICM motor valve core enables the AICM from DN20 to DN150 to be driven by only two sizes of AICAD actuators. The assembly of AICM motor valve and AICAD actuator is very compact.

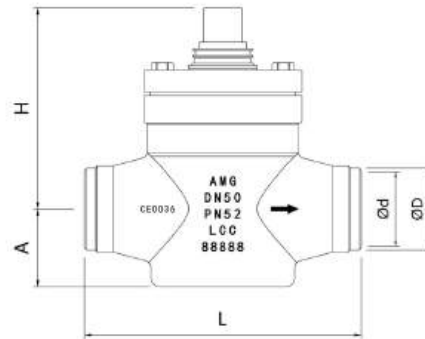
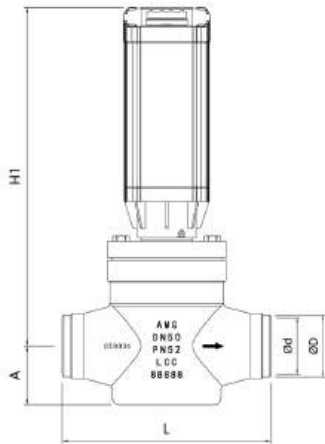

Name	Type	Size(mm)					
		φ D	φ d	A	H	H1	L
AICM Motor valves	AICM 20	27	20	35	114	275	135
	AICM 25	34	25	35	114	275	135
	AICM 32	42	32	40	119	325	145
	AICM 40	48	40	49	137	325	160
	AICM 50	60	50	57	147	335	200
	AICM 65	76	65	65	171	355	230
	AICM 80	89	80	65	171	355	230
	AICM 100	108	100	105	276	460	304
	AICM 125	133	121	120	300	485	350
AICM 150	159	146	175	340	525	445	

Technical parameters

Nominal pressure: 5.2MPa Applicable temperature: -45°C ~ +120°C
 Test pressure: 7.8MPa Applicable medium: Ammonia, Freon, CO₂, etc.

Characteristics

- Actuator types AICAD 600 and AICAD 1200 are dedicated for use with AICM motor operated valves. There are only two sizes of AICAD actuators that cover the range of valves from AICM 20 to AICM 150.
- The AICAD is controlled via a modulating analogue signal (e.g. 4-20 mA/2-10 V) or a digital ON/OFF signal. AICAD incorporates an advanced MMI (Man Machine Interface), including continuous display of Opening Degree, which gives the user a very advanced and flexible setup procedure that can meet many different applications.

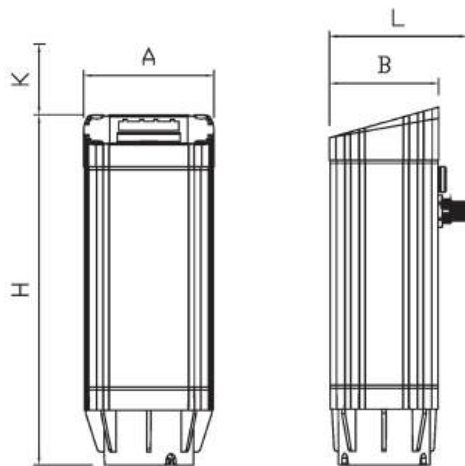

Features (actuator)

- Designed for industrial refrigeration installations.
- Advanced and high speed Digital Stepper Motor Technology
- Seven segment LCD display and three programming keys included
- Valve opening degree can be observed continuously.
- Can easily be configured to different applications on-site (change speed, ON/OFF, Fail Safe operation, modulating valve, etc..)
- Modulating, ON/OFF operation or Neutral zone / 3 point control
- Multiple speed selection during operation
- Logging of old alarms
- One or two digital inputs.
- 3 Digital ON/OFF feedback
- Auto Calibration, Neutral zone
- In the event of a power failure, multiple fail safe options are possible. During power failure, AICM can be selected to:
 - Close AICM,
 - Open AICM,
 - Stay in the same position, as when power failure occurs
 - Go to a specific AICM valve opening degree
- Hermetic magnetic motor
- Connectors for easy installation and servicing
- AICAD 600/1200 ensures an accurate feedback on the valve position.
- Password protection

Name	Type	Size(mm)					Weight (Kg)
		A	H	K	L	B	
AICD Actuator	AICAD 600	76	195	40	102	70	1.3
	AICAD 1200	76	219	45	102	70	1.9

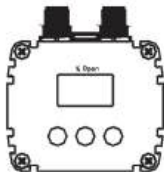

Type	Power supply	Current load	Connection	Grade	Temperature (°C)	AICM Valve-Compatible
AICAD 600	24VDC	1.2A	M12	IP67	-30°C ~ +50°C	AICM 20-32
AICAD 1200		2.0A				AICM 40-150

Technical parameters

Nominal pressure: 5.2MPa Applicable temperature: -45°C ~ +120°C
 Test pressure: 7.8MPa Applicable medium: Ammonia, Freon, CO₂, etc.



AICF15/20-2-121

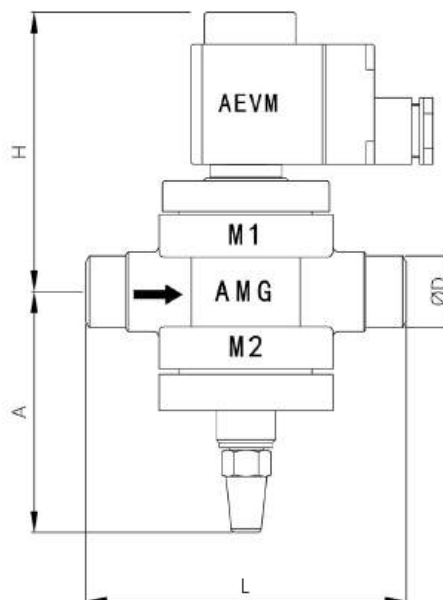

Name	Type	DN	Size(mm)			
			φ D	A	H	L
AICF Solenoid valve	AICF15-2-121	DN15	21	90	99	120
	AICF20-2-121	DN20	27			

Combination valve AICF

Technical parameters

Nominal pressure: 5.2MPa

Applicable temperature: -45°C ~ +120°C

Test pressure: 7.8MPa

Applicable medium: Ammonia, Freon, CO₂, etc.

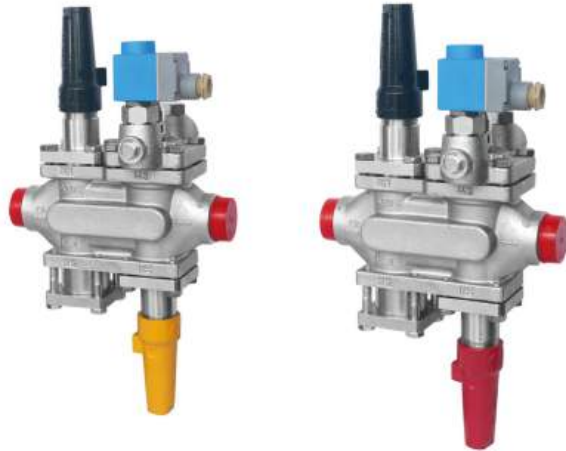

Characteristics

- The AICF combination valve integrates multiple functions into one, which can replace a series of traditional mechanical valves, solenoid valves, and electric valves.
- AICF combination valve is designed for low-pressure and high pressure refrigerants and can be used in discharge pipelines, hot gas pipelines, and liquid pipelines.
- The V-shaped flow port on the control module ensures optimal adjustment accuracy, especially under partial load conditions.
- AICF has four or six modules, and the modular concept provides multiple different interface types and sizes for each valve body. Valve maintenance is achieved through maintenance or replacement of functional modules.
- The side interface can be connected to pressure gauges, sensors, sight glasses, etc.

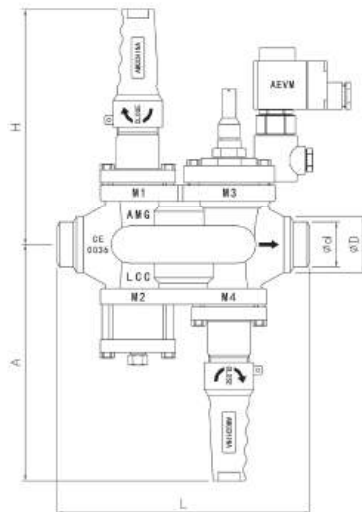
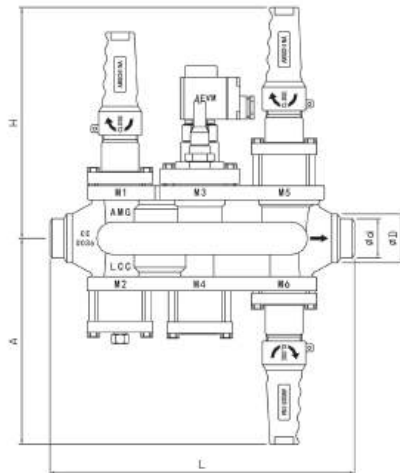

Name	Type	DN	Size(mm)				
			φ D	φ d	A	H	L
AICF Combination valve	AICF 20-4	DN20	34	25	170	95	180
		DN25	21	15			
	AICF 20-6	DN20	27	20	170/270	170	250
		DN25	34	25			
	AICF 25-4	DN25	34	25	220	220/265	235
		DN32	42	32			
		DN40	48	40			
	AICF 25-6	DN25	34	25	220/280	220/265	325
		DN32	42	32			
		DN40	48	40			

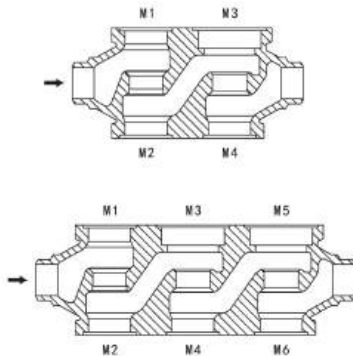

Code	Model	Code	Model
AICFS	Stop valve	AICFC	Check valve
AICFR	Regulating valve A or B	AICFN	Stop check valve
AICFF	Filter	AICM	A or B electric valve
AICFE	Solenoid valve	AICFB	Blind plate top cover
AICFO	Manually activate valve	AICFW	Welding

General configuration(excluding interface type and size)						
Application	M1	M2	M3	M4	M5	M6
Liquid supply pipeline						
Liquid supply pipeline (no hot air defrosting)	Stop valve	Filter	Solenoid valve	Manually open	Regulating valve	Stop valve
Liquid supply pipeline	Stop valve	Filter	Solenoid valve	Manually open	Regulating valve	Stop Check Valve
Liquid supply pipeline	Stop valve	Filter	Solenoid valve	Check valve	Regulating valve	Stop valve
Liquid supply pipeline (no hot air defrosting)	Stop valve	Filter	Solenoid valve	Regulating valve		
Liquid supply pipeline with external connection	Stop valve	Filter	Solenoid valve	Check valve	Welding valve	Regulating valve
Common applications of solenoid valves						
Solenoid valve-liquid and hot gas pipelines	Stop valve	Filter	Solenoid valve	Manually open	Stop valve	
Solenoid valve-liquid and hot gas pipelines	Stop valve	Filter	Solenoid valve	Manually open		
Liquid jet						
Liquid jet (expansion)	Stop valve	Filter	Solenoid valve	Manually open	Electric motor	Stop valve
Liquid jet (expansion) PWM	Stop valve	Filter	Electric valve	Stop valve		
Liquid jet (expansion)	Stop valve	Filter	Solenoid valve	Stop valve		
Hot gas defrosting						
Hot gas defrosting	Stop valve	Filter	Solenoid valve	Stop valve		
Solenoid valve-multiple evaporators						
Solenoid valve-multiple evaporators	Stop valve	Filter	Solenoid valve	Check valve		
Solenoid valve-multiple evaporators	Stop valve	Filter	Solenoid valve	Stop Check Valve		
PWM Liquid PWM						
PWM Control for Liquid Jet and Injection	Stop valve	Filter	Electric valve	Stop Check Valve		

Technical parameters

Nominal pressure: 5.2MPa Applicable temperature: -45°C ~ +120°C
 Test pressure: 7.8MPa Applicable medium: Ammonia, Freon, CO₂, etc.

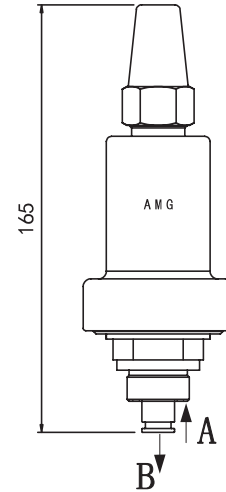
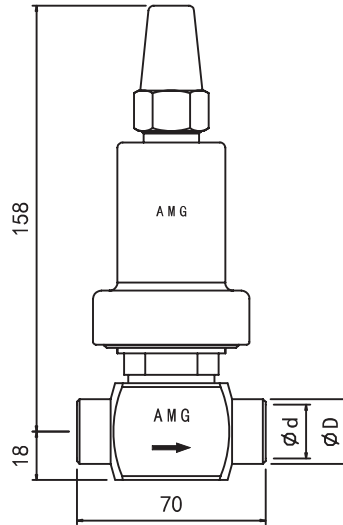

Characteristics

- Pilot valves are intended for mechanical control of a main valve and are ready for direct installation in the top cover of the main valve AM3,AICS3.
- This pilot valve is used for maintaining a constant pressure on the inlet side of the main valve.
- When a ACVP is mounted in a ACVH housing, it can be used as a separate constant-pressure valve or a pressure relief valve (e.g.to prevent hydraulic overpressurein an entrapped liquid)

Pilot Valve Type	MWP(bar)	KV(m ³ /h)	Temperature Range(°C)	Pressure Range(bar)
ACVP-L	52	0.4	-45/+120	-0.65-10

Technical parameters

Nominal pressure: 5.2MPa Applicable temperature: -45°C ~ +120°C
 Test pressure: 7.8MPa Applicable medium: Ammonia, Freon, CO₂, etc.

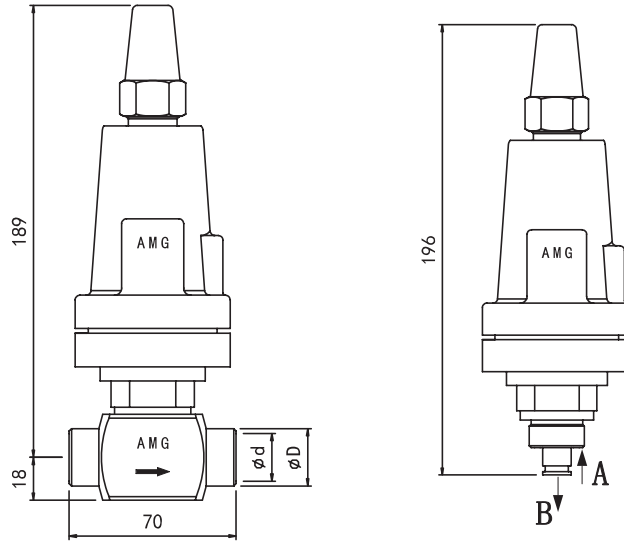

Characteristics

- Pilot valves are intended for mechanical control of a main valve and are ready for direct installation in the top cover of the main valve AM3,AICS3.
- This pilot valve is used for maintaining a constant pressure on the inlet side of the main valve.
- When a ACVP is mounted in a ACVH housing, it can be used as a separate constant-pressure valve or a pressure relief valve (e.g.to prevent hydraulic over pressure in an entrapped liquid)
- ACVP valves are available in 2 modifications with different setting ranges:
 - ACVP-H:4 bar to 25 bar
 - ACVP-X:10 bar to 52 bar

Pilot Valve Type	MWP(bar)	KV(m ³ /h)	Temperature Range(°C)	Pressure Range(bar)
ACVP-H	52	0.4	-45/+120	4-25
ACVP-X	52	0.4	-45/+120	10-52

Technical parameters

Nominal pressure: 5.2MPa Applicable temperature: -45°C ~ +120°C
 Test pressure: 7.8MPa Applicable medium: Ammonia, Freon, CO₂, etc.

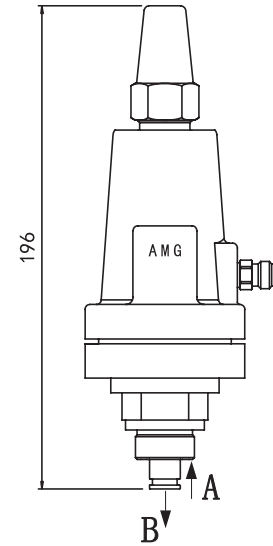
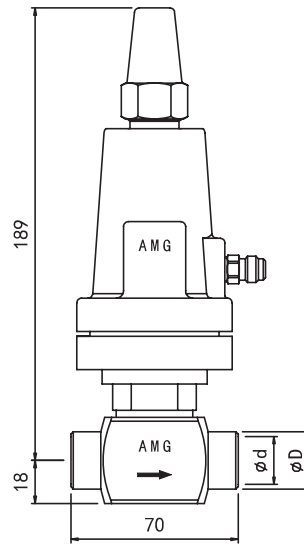

Characteristics

- Pilot valves are intended for mechanical control of a main valve and are ready for direct installation in the top cover of the main valve AM3,AICS3.When a ACVPP is mounted in a ACVH housing, it can be used as a separate constant-pressure valve or a pressure relief valve (e.g. to prevent hydraulic overpressure in an entrapped liquid).
- ACVPP pilot valve is used for maintaining a constant differential pressure between the ACVPP valve reference pressure connection and the main valve inlet pressure.

Pilot Valve Type	MWP(bar)	KV(m ³ /h)	Temperature Range(°C)	Pressure Range(bar)
ACVPP	52	0.4	-45/+120	0-10

Technical parameters

Nominal pressure: 5.2MPa Applicable temperature: -45°C ~ +120°C
 Test pressure: 7.8MPa Applicable medium: ammonia, freon, CO₂, etc.

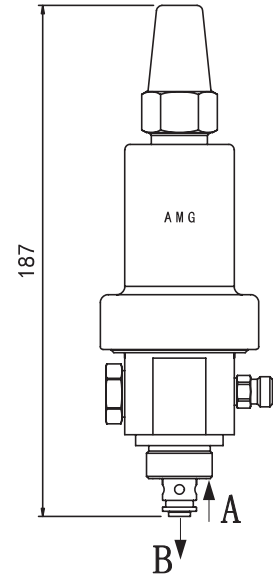
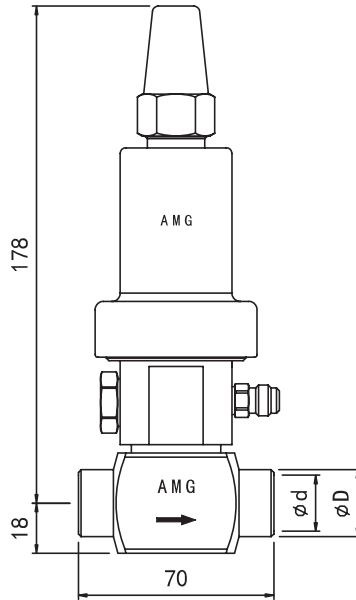

Characteristics

- Pilot valves are intended for mechanical control of a main valve and are ready for direct installation in the top cover of the main valve AM3, AICS3. The ACVC-pilot is designed to maintain a constant pressure at an external reference point in the system.
- When a ACVC is mounted in a ACVH housing, it can be used as a separate constant-pressure valve or a pressure relief valve (e.g. to prevent hydraulic over pressure in an entrapped liquid).

Pilot Valve Type	MWP(bar)	KV(m ³ /h)	Temperature Range(°C)	Pressure Range(bar)
ACVC-L	52	0.4	-45/+120	0.5-10
ACVC-H	52	0.4	-45/+120	4-25

Technical parameters

Nominal pressure: 5.2MPa Applicable temperature: -45°C ~ +120°C
 Test pressure: 7.8MPa Applicable medium: Ammonia, Freon, CO₂, etc.

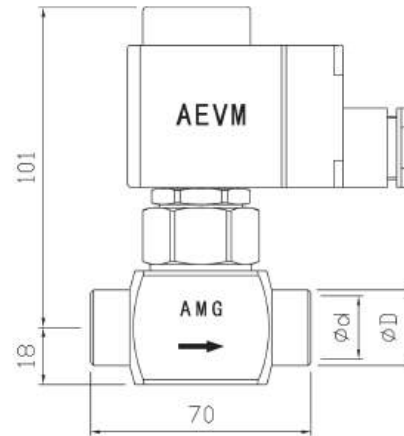

Characteristics

- Pilot valves are intended for mechanical control of a main valve and are ready for direct installation in the top cover of the main valve AM3,AICS3.
- AEVM is a solenoid pilot valve for use when on/off operation of the main valve is required. Together with ACVH, an AEVM can also be used as an independent solenoid valve.
- AEVM valves are available in 2 modifications:
 AEVM-NC-normally closed
 AEVM-NO-normally opened

Pilot Valve Type	Voltage (V)	Frequency (HZ)	Power (W)
Coil	220-230	50/60	10
Coil	220-230	50/60	12
Coil	220-230	50/60	15
Coil	220-230	50/60	18

Pilot Valve Type	MWP(bar)	KV(m ³ /h)	Maximum Operating ΔP (bar)
AEVM-NC	52	0.37	21
AEVM-NO	52	0.37	21



Characteristics

- AEVRA is a direct or servo operated solenoid valve for liquid, suction and hot gas lines with ammonia or fluorinated refrigerants.
- AEVRAT is an assisted lift, servo operated solenoid valve for liquid, suction and hot gas lines with ammonia and fluorinated refrigerants. AEVRAT is specially designed to open - and stay open - at a pressure drop of 0 bar.
- AEVRAT 10-15 and AEVRA 20-25 have spindle for manual operation.

Technical parameters

Type	Opening pressure differential with standard coil (ΔP bar)				Max.working pressure, bar g	Kv ⁽²⁾ m ³ /h
	Min.	Max. (=MOPD)liquid ⁽¹⁾				
		10w AC	12w AC	20w DC		
AEVRAT10	0.00	14	21	16	40	1.5
AEVRAT15	0.00	14	21	16	40	2.7
AEVRA20	0.20	21	25	16	40	4.5
AEVRA25	0.20	21	25	14	40	10.0
AEVRA32	0.20	21	25	14	40	16.0
AEVRA40	0.20	21	25	14	40	25.0
AEVRA50	0.20				40	



(1) MOPD for media in gas form is approx. 1 bar greater

(2) The kv value is the water flow in m³/h at a pressure drop across valve of 1 bar, $p = 1000 \text{ kg/m}^3$

The rated cooling capacity test conditions for the liquid line and suction line are: evaporating temperature $t_e = -10^\circ\text{C}$, liquid temperature at valve inlet $t_i = 25^\circ\text{C}$, valve pressure differential $\Delta P = 0.15 \text{ bar}$. The rated cooling capacity test conditions for the discharge line are: condensing temperature $t_c = 40^\circ\text{C}$, valve pressure differential $\Delta P = 0.8 \text{ bar}$, discharge gas temperature $t_g = 65^\circ\text{C}$, subcooling degree $\Delta t_{\text{sub}} = 4\text{K}$.

AFA15-25 filter

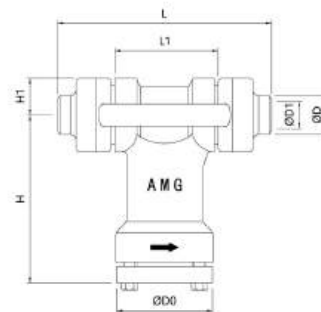

Name	Type	Size(mm)						
		ϕD	ϕd	L1	L	H	H1	$\phi D0$
Filter	AFA10	14	10	56	115	90	20	53
	AFA15	21	15	56	115	90	20	53
	AFA20	27	20	75	140	100	25	59
	AFA25	34	25	75	140	100	25	59

Technical parameters

Nominal pressure: 5.2MPa Applicable temperature: -45°C ~ +120°C
 Test pressure: 7.8MPa Applicable medium: Ammonia, Freon, CO₂, etc.

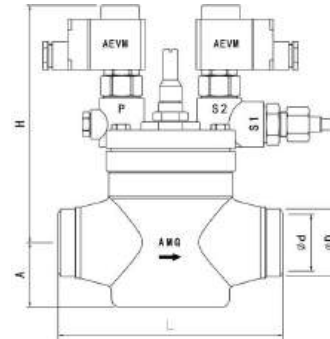

Characteristics

- AICLX are two steps servo-operated normally close valves with screwed-on pilot solenoid valves. Valves use an external pressure source for opening (which means that no differential pressure across the AICLX valve is required).
- AICLX are used in suction lines for the opening against high differential pressure, e.g. after hot gas defrost in large industrial refrigeration systems with ammonia or fluorinate refrigerants.
- AICLX opens in two steps:
 - Step one opens to approx. 10% of the capacity, when the pilot solenoid valves are activated.
 - Step two opens automatically after the pressure differential across the valve reaches approximately 1-1.5 bar.

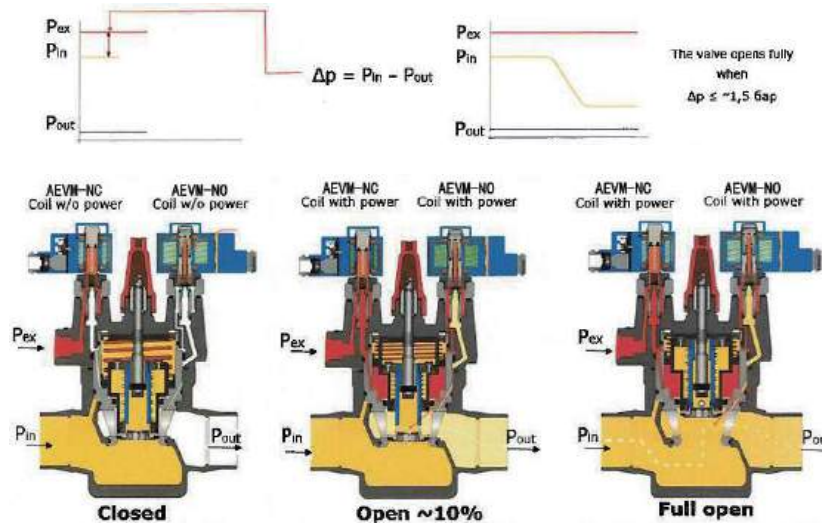

Name	Type	Size(mm)					kv	Cv
		φ D	φ d	A	H	L		
AICLX Two step opening defrosting solenoid valve	AICLX 32	42	32	49	150	245	16	19
	AICLX 40	48	40	49	150	245	30	35
	AICLX 50	60	50	57	170	255	40	47
	AICLX 65	76	65	65	195	295	75	88
	AICLX 80	89	80	65	195	330	140	164
	AICLX 100	108	100	105	380	415	200	234
	AICLX 125	133	121	120	392	430	207	240
AICLX 150	159	146	175	433	445	354	410	

Technical parameters

Nominal pressure: 2.8MPa Applicable temperature: -45°C ~ +120°C
 Test pressure: 4.2MPa Applicable medium: Ammonia, Freon, CO₂, etc.

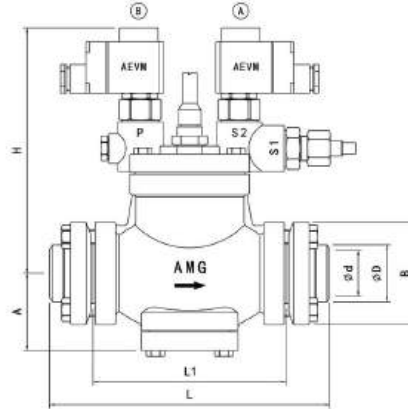

Characteristics

- AMLX are two steps servo-operated normally close valves with screwed-on pilot solenoid valves. Valves use an external pressure source for opening (which means that no differential pressure across the AMLX valve is required).
- AMLX are used in suctionlines for the opening against high differential pressure, e.g. after hot gas defrost in large industrial refrigeration systems with ammonia or fluorinate refrigerants
- AMLX opens in two steps:
 Step one opens to approx. 10% of the capacity, when the pilot solenoid valves are activated.
 Step two opens automatically after the pressure differential across the valve reaches approximately 1-1.5 bar.

Name	Type	Size(mm)						kv	Cv
		φ D	φ d	A	H	L	L1		
AMLX Two step opening defrosting solenoid valve	AMLX 32	42	32	70	215	245	170	16	19
	AMLX 40	48	40	70	215	245	170	30	35
	AMLX 50	60	50	70	220	255	180	40	47
	AMLX 65	76	65	85	245	295	220	75	88
	AMLX 80	89	80	95	265	330	250	140	164
	AMLX 100	108	100	125	300	415	330	200	234
	AMLX 125	133	121	120	405	350	/	207	240
	AMLX 150	159	146	150	445	445	/	354	410

Technical parameters

Nominal pressure: 4.0MPa Applicable temperature: -45°C ~ +65°C
 Test pressure: 6.0MPa Applicable medium: Ammonia, Freon, CO₂, etc.

Microelectronic single pole double throw switches have two functions: normally open and normally closed 250Va.c/10A 30Vd.c/5A

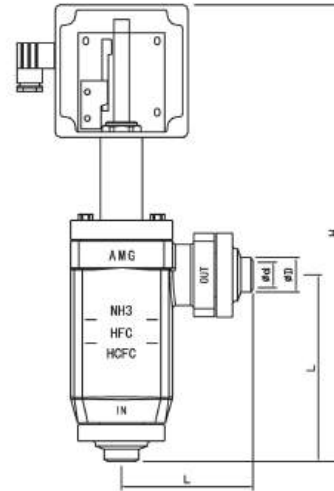

Characteristics

- AKS38 is an electromechanical float level switch designed and produced based on the principles of buoyancy and magnetic field. It can send switching signals according to changes in liquid level, and can also be used as an alarm for high/low liquid levels.
- The position of the floating ball changes due to the change of the liquid level inside the valve body, and when the contact point of the floating ball enters the micro electricity. In the sub switch magnetic field, switching signals are generated under the action of magnetic force to achieve automatic control the process of liquid level.
- The liquid level adjustment range is between 12.5mm and 50mm, and the adjustment step is 12.5mm. The factory default setting is 50mm.

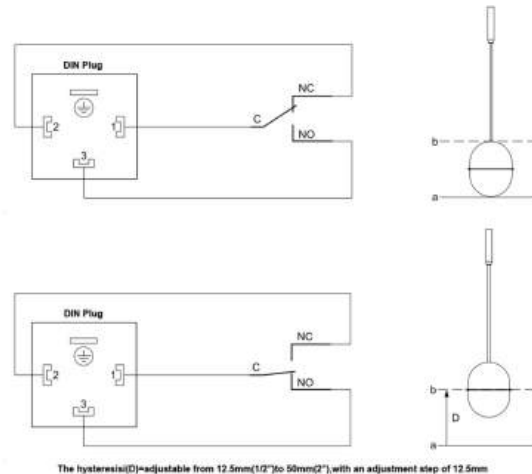

The hysteresis(D)=adjustable from 12.5mm(1/2")to 50mm(2"), with an adjustment step of 12.5mm

Name	Type	Size(mm)		
		H	L	L1
AKS38 Liquid level switch	ASK38-20	400	121	177
	ASK38-25			

Technical parameters

Nominal pressure: 5.2MPa Applicable temperature: -45°C ~ +120°C
 Test pressure: 7.8MPa Applicable medium: Ammonia, Freon, CO₂, etc.

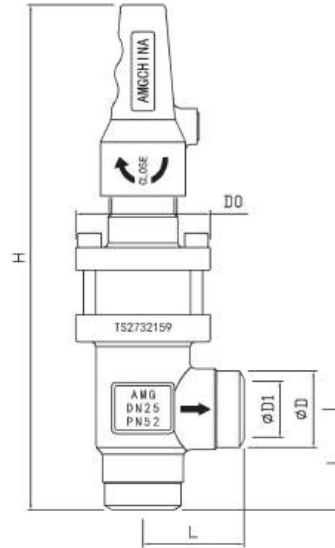

Characteristics

- FOV are angle-way pressure regulating valves, which have adjustable opening pressure and cover the differential pressure range (AP): 2-8 bar. The valve can be closed manually, e.g. during plant service and have backseating, enabling the spindle seal to be replaced with the valve still under pressure.
- The valves are especially designed to prevent fluttering due to low velocity and/or low density. In consequence it is possible to apply the valves with wide fluctuations in capacity demands, i.e. from maximum performance to partload. A flexible O-ring provides perfect sealing over the seat.

Name	Type	Size(mm)				
		φ D	φ D1	L	D0	H
FOV Relief valve	FOV 20	27	20	45	□ 60	225
	FOV 25	32	25	45	□ 60	225
	FOV 32	38	32	55	□ 70	295
	FOV 40	45	40	55	□ 70	295

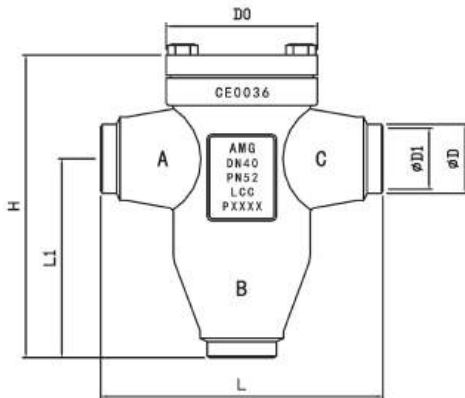

Technical parameters

Minimum Operating Temperature: $\geq -10^{\circ}\text{C}$
 Continuous Operating Temperature: $\leq +85^{\circ}\text{C}$
 Short-term Operating Temperature: $\leq +120^{\circ}\text{C}$
 Maximum Working Pressure: 52 bar
 Oil Compatibility:
 Suitable for all common refrigeration oils.
 Refrigerant Compatibility:
 Compatible with all standard refrigerants and non-corrosive gases/liquids, including ammonia (R717), fluorocarbons, carbon dioxide, propane, propylene, etc. (Seal material compatibility must be verified).
 For further information, please contact AMG Company.

Characteristics

- Optimized fluid flow design
- High resistance to vibration and shock
- Stainless steel thermostatic control element
- No manual adjustment required
- Easy maintenance and disassembly
- Available with butt-weld or socket-weld connections

ROV are 3-way industrial valves for maintaining a constant oil temperature in gas compressor systems, by mixing hot and cold oil in the lubricating system of e.g. screw or turbotype compressors. The ROV valves are with few components and with extended cylindrical connections, to ensure ease of installation and service. ROV valve can work as a mixing or diverting valve. The ROV temperature regulating valve utilises the high coefficient of thermal expansion of wax to create the internal movement necessary to have a cold and a hot inlet mixing to a common outlet. The outlet temperature will correspond to the nominal temperature of the thermostatic element.

The valve house has three ports:

- Port A is used for the common outlet
- Port B is for the hot inlet
- Port C is for the cold inlet

Two types of thermostatic elements 49°C and 60°C . Thermostatic elements are made of stainless steel. Easy to maintain and does not require manual adjustment. High resistance to vibration or shock. Can be installed in any position. Valves are available with butt-welded type connections.

Name	Type	Size(mm)					
		ϕD	ϕd	L	D0	L1	H
ROV Oil temperature control valve	ROV 25	32	25	165	\square 95	110	175
	ROV 32	38	32	165	\square 95	110	175
	ROV 40	45	39	196	\square 105	138	210
	ROV 50	57	50	196	\square 105	138	210
	ROV 65	76	65	250	\square 135	155	250
	ROV 80	89	80	250	\square 135	155	250

Technical parameters

Nominal pressure: 4.0MPa Applicable temperature: -45°C ~ +150°C
 Test pressure: 6.0MPa Applicable medium: Ammonia.

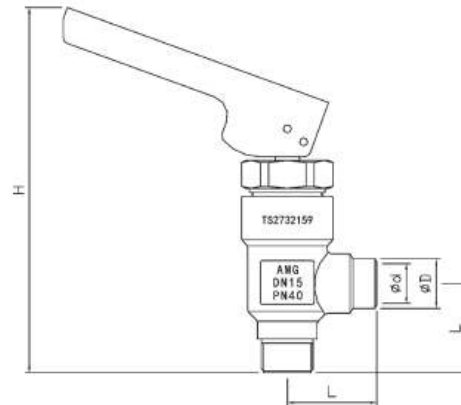

Characteristics

- AQDV is a shut-off valve, designed particularly for draining oil from systems containing refrigerant (ammonia) under pressure. The valve will close immediately on release of the handle, thus protecting user and environment against unnecessary refrigerant leaks. In order to prevent hydraulic pressure building up between the stop valve and the AQDV an integral relief device is included as part of the cone arrangement, which will open at approx 16 bar.
- AQDV is designed to meet the safety demands specified by national and international authorities within industrial refrigeration.

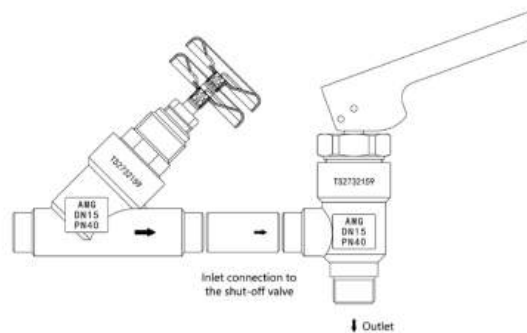

Name	Type	Size(mm)		
		H	L	L1
AQDV Quick Drain Valve	AQDV15	185	45	45
	AQDV20			

Safety valve ASFV

Technical parameters

Nominal pressure: 5.2MPa Applicable temperature: $-45^{\circ}\text{C} \sim +120^{\circ}\text{C}$
 Test pressure: 7.8MPa Applicable medium: Ammonia, Freon, CO_2 , etc.

Characteristics

- ASFV are standard, back pressure dependent safety relief valves in angleway execution, specially designed for protection of vessels and other components against excessive pressure.
- The valve is designed to meet the strict quality demands and safety requirements for refrigeration installations, specified by the international classification societies.
- The valve is recommended as an external and internal safety relief valve in refrigeration plants. The spring housing is closed tightly to avoid refrigerant leakage. The inlet flow diameters of the valves are shown in below table.
- The valves can be delivered with set pressures between 12 to 40 bar g. (step 1 bar)
- The safety relief valve should be fully open before the pressure is 10% higher than set pressure, and fully closed before the pressure is 10% below set pressure (See fig. below)



ASFV-D

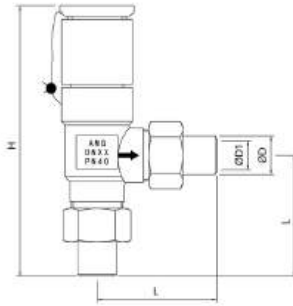

ASFV

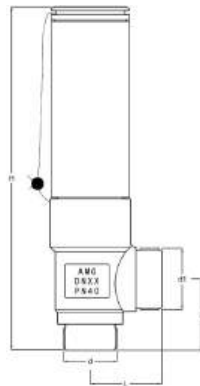

ASFV-F

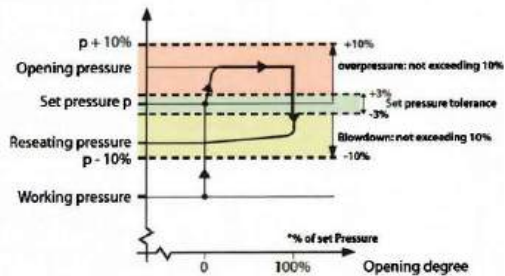
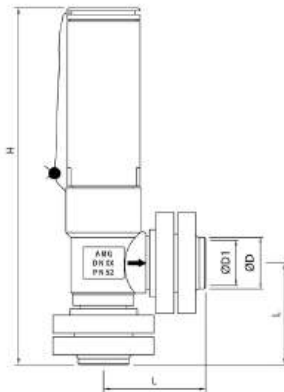

Name	Type	Size(mm)						
		L	H	D	D1	d	d1	inlet flow diametes
ASFV Safety valve	ASFV15-D	78	175	21.3	15	/	/	16
	ASFV20-D	78	175	25	19	/	/	16
	ASFV25-D	91	213	34	25	/	/	22
	ASFV20	55	265	/	/	G1-1/4	G1-1/2	18
	ASFV25	55	265	/	/	G1-1/4	G1-1/2	23
	ASFV32	55	265	/	/	G1-1/4	G1-1/2	23
	ASFV20-F	85	300	27	19	/	/	18
	ASFV25-F	85	300	34	25	/	/	23
	ASFV32-F	85	300	38	32	/	/	23

Technical parameters

Nominal pressure: 5.2MPa Applicable temperature: -45°C ~ +120°C
 Test pressure: 7.8MPa Applicable medium: Ammonia, Freon, CO₂, etc.

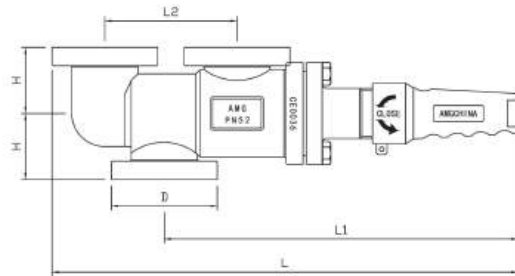
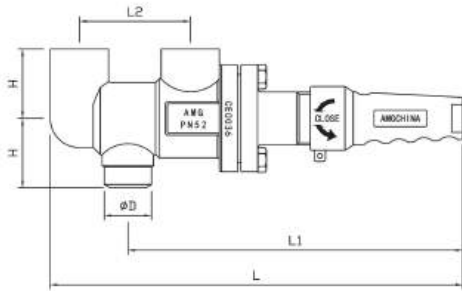

Characteristics

- ADSV are 3-way valves, which are designed to meet all industrial refrigeration application requirements. ADSV valves are designed specifically for use with double safety valve systems.
- The valves are designed to give favourable flow characteristics and are easy to dismantle for servicing. The valve cone is designed to ensure perfect closing, even with minimum torque the valve will close effectively. All valves are equipped with vented cap and nipple/flange connections, which permit easy inspection or replacement of safety valves.



Name	Type	Size(mm)					Weight (Kg)
		D	H	L	L1	L2	
ADSV Three way stop valve	ADSV1	34	50	300	245	80	3.6
	ADSV2	80	50	355	270	100	6.1

Name	Type	Size(mm)		
		ADSV Inlet	ADSV Outlet	ASFV Outlet
ADSV Three way stop valve	ADSV 1	DN20	G3/4 " or M33*2 Connector	DN20
	ADSV 1	DN25	G3/4 " or M33*2 Connector	DN20
	ADSV 2	DN20	G1-1/4 " Threaded Flange	DN20
	ADSV 2	DN25	G1-1/4 " Threaded Flange	DN25
	ADSV 2	DN32	G1-1/4 " Threaded Flange	DN32

Technical parameters

Nominal pressure: 4.0MPa Applicable temperature: -45°C ~ +150°C
 Test pressure: 6.0MPa Applicable medium: Ammonia, Freon, CO₂, etc.

Characteristics

RVY/RVT stop valves are designed to completely shut off the flow of the working medium moving through the pipeline. Valves are available in angle and straight. The shut-off valves are designed to meet all industrial refrigeration application requirements and are designed to give favourable flow characteristics and are easy to dismantle and repair when necessary. The valve cone is designed to ensure perfect closing and withstand a high system pulsation and vibration, which can be present specifically in the discharge line.

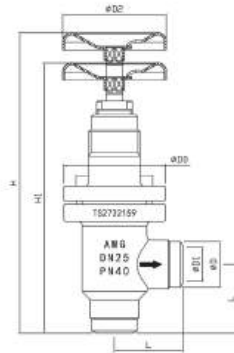
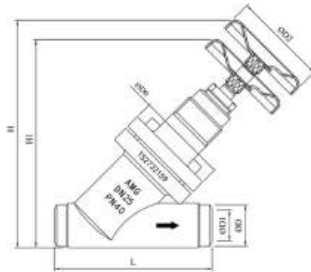

RVY15-80 Forged steel straight stop valve

RVT15-80 Forged steel angle stop valve

Name	Type	Size(mm)							Weight (Kg)
		φD	φD1	L	H1	H	φD0	φD2	
RVY Straight stop valve	RVY15	21	15	106	137	147	65	60	1.3
	RVY20	27	20	106	140	150	65	60	1.4
	RVY25	34	25	128	170	186	75	80	2.3
	RVY32	42	32	128	174	190	75	80	2.5
	RVY40	48	40	165	218	250	95	100	4.1
	RVY50	60	50	165	225	258	95	100	4.5
	RVY65	76	65	195	270	295	□105	120	8.8
	RVY80	89	80	212	305	350	□115	160	10.3

Name	Type	Size(mm)							Weight (Kg)
		φD	φD1	L	H1	H	φD0	φD2	
RVT Angle stop valve	RVT15	21	15	40	168	183	65	60	1.2
	RVT20	27	20	40	168	183	65	60	1.3
	RVT25	34	25	51	200	223	75	80	2.1
	RVT32	42	32	51	200	223	75	80	2.2
	RVT40	48	40	60	246	290	95	100	3.8
	RVT50	60	50	64	246	290	95	100	4.0
	RVT65	76	65	75	265	300	□105	120	7.2
	RVT80	89	80	80	305	345	□115	160	8.3

Technical parameters

Nominal pressure: 4.0MPa Applicable temperature: -45°C ~ +150°C
 Test pressure: 6.0MPa Applicable medium: Ammonia, Freon, CO₂, etc.

Characteristics

RRY/RRT control valve are angleway and straightway hand operated regulating valves, which act as normal shut-off valves in closed position. The valves are designed to meet the strict quality requirements on refrigerating installations specified by the international classification societies and are carefully designed to present favourable flow conditions and accurate linear characteristics.

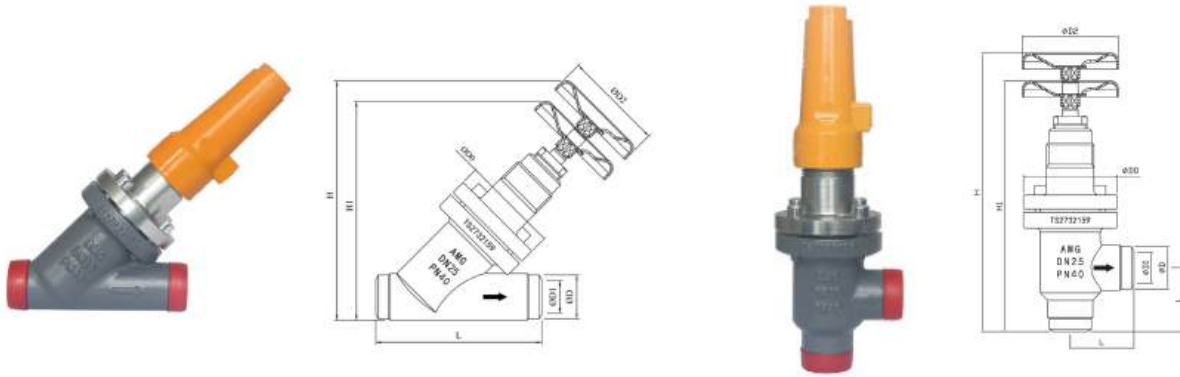

RRY15-80 Forged steel straight regulating valve

RRT15-80 Forged steel angle regulating valve

Name	Type	Size(mm)							Weight (Kg)
		φD	φD1	L	H1	H	φD0	φD2	
RRY Straight regulating stop valve	RRY15	21	15	106	137	147	65	60	1.4
	RRY20	27	20	106	140	150	65	60	1.5
	RRY25	34	25	128	170	186	75	80	2.4
	RRY32	42	32	128	174	190	75	80	2.5
	RRY40	48	40	165	218	250	95	100	4.5
	RRY50	60	50	165	225	258	95	100	4.9
	RRY65	76	65	195	270	295	□105	120	9.3
	RRY80	89	80	212	305	350	□115	160	11

Name	Type	Size(mm)							Weight (Kg)
		φD	φD1	L	H1	H	φD0	φD2	
RRT Angle regulating stop valve	RRT15	21	15	40	168	183	65	60	1.3
	RRT20	27	20	40	168	183	65	60	1.4
	RRT25	34	25	51	200	223	75	80	2.2
	RRT32	42	32	51	200	223	75	80	2.3
	RRT40	48	40	60	246	290	95	100	4.1
	RRT50	60	50	64	246	290	95	100	4.2
	RRT65	76	65	75	265	300	□105	120	7.7
	RRT80	89	80	80	305	345	□115	160	9.1

Technical parameters

Nominal pressure: 4.0MPa Applicable temperature: -45°C ~ +150°C
 Test pressure: 6.0MPa Applicable medium: Ammonia, Freon, CO₂, etc.

Characteristics

Stop-check valves type VCY/VCT allow the medium to flow in one direction and prevent it from flowing in the opposite direction. The valves are available in angle and straight-flow versions and have an integrated shut-off function.

The valves are designed to open at very low differential pressures, allow favourable flow conditions and are easy to disassemble for inspection and service.

The valve cone has a built-in flexibility to ensure a precise and tight closing towards the valve seat. A well balanced dampening effect between the piston and the cylinder gives an optimal protection during low loads and against pulsations.

The valves meet all the requirements for industrial refrigeration equipment.

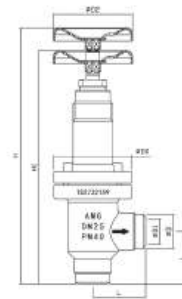
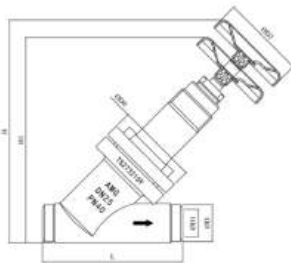

VCY15-80 Forged steel straight stop check valve

VCT15-80 Forged steel angle stop check valve

Name	Type	Size(mm)							Weight (Kg)
		φD	φD1	L	H1	H	φD0	φD2	
VCY Straight stop check valve	VCY15	21	15	106	150	165	65	60	1.5
	VCY20	27	20	106	155	170	65	60	1.6
	VCY25	34	25	128	190	207	75	80	2.4
	VCY32	42	32	128	193	210	75	80	2.8
	VCY40	48	40	165	237	264	95	100	4.8
	VCY50	60	50	165	243	270	95	100	5.1
	VCY65	76	65	195	295	335	□105	120	8.7
	VCY80	89	80	212	326	365	□115	160	10

Name	Type	Size(mm)							Weight (Kg)
		φD	φD1	L	H1	H	φD0	φD2	
VCT Angle stop check valve	VCT15	21	15	40	190	210	65	60	1.3
	VCT20	27	20	40	190	210	65	60	1.4
	VCT25	34	25	51	227	253	75	80	2.4
	VCT32	42	32	51	227	253	75	80	2.5
	VCT40	48	40	60	276	313	95	100	4.2
	VCT50	60	50	64	276	313	95	100	4.4
	VCT65	76	65	75	300	355	□105	120	7.4
	VCT80	89	80	80	335	386	□115	160	8.2

Technical parameters

Nominal pressure: 4.0MPa	Applicable temperature: -45°C ~ +150°C
Test pressure: 6.0MPa	Applicable medium: Ammonia, Freon, CO ₂ , etc.

Characteristics

Check valves type RCY/RCT allow the medium to flow in one direction and prevent it from flowing in the opposite direction. The valves are available in angle and straight-flow versions.

The valves are designed to open at very low differential pressures, allow favourable flow conditions and are easy to disassemble for inspection and service.

The valve cone has a built-in flexibility to ensure a precise and tight closing towards the valve seat. A well balanced dampening effect between the piston and the cylinder gives an optimal protection during low loads and against pulsations.

The valves meet all the requirements for industrial refrigeration equipment.

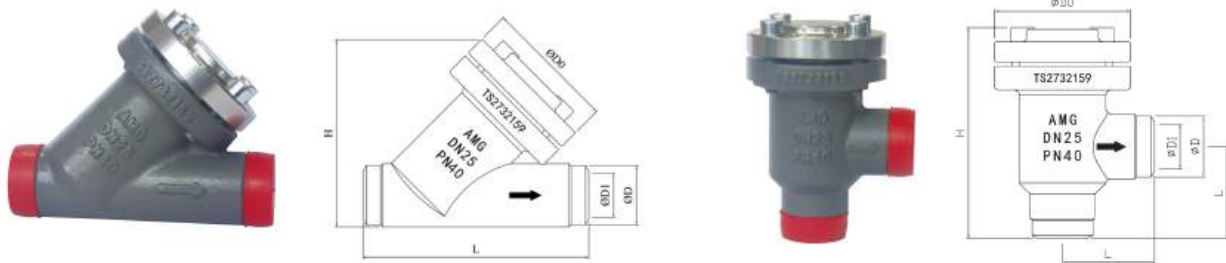

RCY15-80 Forged steel straight check valve

RCT15-80 Forged steel angle check valve

Name	Type	Size(mm)					Weight (Kg)
		φ D	φ D1	L	H	φ D0	
RCY Straight check valve	RCY15	21	15	106	87	65	1.4
	RCY20	27	20	106	89	65	1.5
	RCY25	34	25	128	106	75	2.4
	RCY32	42	32	128	110	75	2.5
	RCY40	48	40	165	140	95	4.5
	RCY50	60	50	165	146	95	4.9
	RCY65	76	65	195	175	□105	9.3
	RCY80	89	80	212	193	□115	11

Name	Type	Size(mm)					Weight (Kg)
		φ D	φ D1	L	H	φ D0	
RCT Angle check valve	RCT15	21	15	40	183	65	1.3
	RCT20	27	20	40	183	65	1.4
	RCT25	34	25	51	223	75	2.2
	RCT32	42	32	51	223	75	2.3
	RCT40	48	40	60	290	95	4.1
	RCT50	60	50	64	290	95	4.2
	RCT65	76	65	75	300	□105	7.7
	RCT80	89	80	80	345	□115	9.1

Technical parameters

Nominal pressure: 4.0MPa Applicable temperature: -45°C ~ +150°C
 Test pressure: 6.0MPa Applicable medium: Ammonia, Freon, CO₂, etc.

Characteristics

FIAY/FIAT strainers are used ahead of automatic controls, pumps, compressors etc., for initial plant start-up and where permanent filtration of the refrigerant is required. The strainer reduces the risk of undesirable system breakdowns and reduces wear and tear on plant components. FIAY/FIAT strainers are a range of angleway and straightway strainers, which are carefully designed to give favourable flow conditions. The design makes the strainer easy to install, and ensures quick Strainer inspection and cleaning.

FIAY/FIAT strainers are equipped with a screen mesh of stainless steel, available in sizes 100,150,250 and 500μ(microns*), (Us 150,100,72,38 mesh*). Mesh is the number of threads per inch, μ(microns) is the distance between two threads (1μ=1/1000 mm).

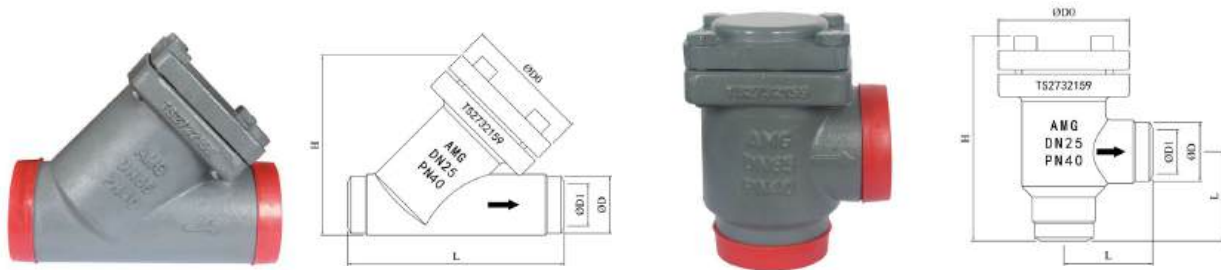

FIA15-80Y Forged steel straight filter

FIA15-80T Forged steel angle Filter

Name	Type	Size(mm)					Weight (Kg)
		φ D	φ D1	L	H	φ D0	
FIAY Straight filter	FIA15Y	21	15	106	87	65	1.0
	FIA20Y	27	20	106	89	65	1.1
	FIA25Y	34	25	128	106	75	1.5
	FIA32Y	42	32	128	110	75	1.7
	FIA40Y	48	40	165	140	95	3
	FIA50Y	60	50	165	146	95	3.3
	FIA65Y	76	65	195	175	□105	5.8
	FIA80Y	89	80	212	193	□115	7.1

Name	Type	Size(mm)					Weight (Kg)
		φ D	φ D1	L	H	φ D0	
FIAT Angle filter	FIA15T	21	15	40	92	65	0.9
	FIA20T	27	20	40	92	65	0.9
	FIA25T	34	25	51	110	75	1.2
	FIA32T	42	32	51	110	75	1.4
	FIA40T	48	40	60	138	95	2.4
	FIA50T	60	50	64	138	95	2.7
	FIA65T	76	65	75	150	□105	4.4
	FIA80T	89	80	80	162	□115	5.1

RVY100-300-ZG cast steel straight stop valve

Technical parameters

Nominal pressure: 4.0MPa Applicable temperature: -45°C ~ +150°C
 Test pressure: 6.0MPa Applicable medium: Ammonia, Freon, CO₂, etc.

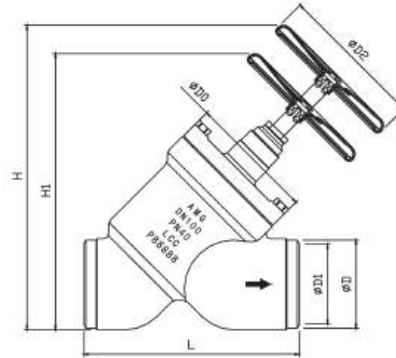

Name	Type	Size(mm)							Weight (Kg)
		φ D	φ D1	L	H1	H	φ D0	φ D2	
RVY-ZG Straight stop valve	RVY100-ZG	108	99	264	340	375	156	180	17
	RVY125-ZG	133	123	322	445	495	193	200	28
	RVY150-ZG	159	149	370	480	540	219	250	38
	RVY200-ZG	219	205	464	615	680	276	350	90
	RVY250-ZG	273	257	550	715	790	334	400	110
	RVY300-ZG	325	305	620	775	850	384	400	150

RVT100-350-ZG cast steel angle stop valve

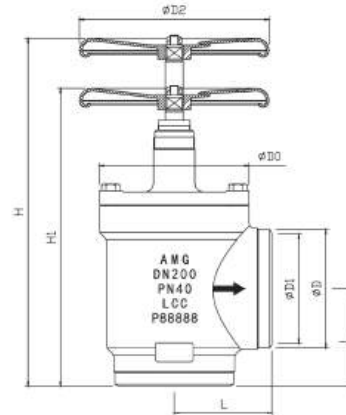

Name	Type	Size(mm)							Weight (Kg)
		φ D	φ D1	L	H1	H	φ D0	φ D2	
RVT-ZG Angle stop valve	RVT100-ZG	108	99	106	325	375	156	180	14
	RVT125-ZG	133	123	128	430	500	193	200	26
	RVT150-ZG	159	149	145	460	545	219	250	33
	RVT200-ZG	219	205	180	550	645	276	350	70
	RVT250-ZG	273	257	210	620	725	334	400	100
	RVT300-ZG	325	305	240	655	760	384	400	130
	RVT350-ZG	377	355	430	720	820	430	500	175

RVY100-450 Welding straight stop valve



Technical parameters

Nominal pressure: 2.5MPa Applicable temperature: -45°C ~ +150°C
 Test pressure: 3.75MPa Applicable medium: Ammonia, Freon, CO₂, etc.

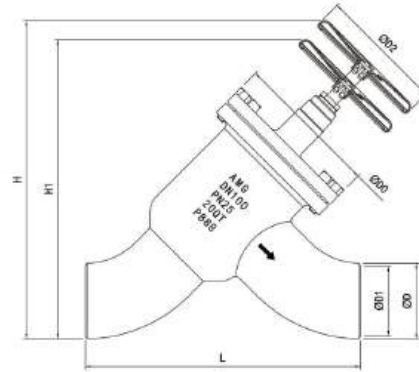

Name	Type	Size(mm)							Weight (Kg)
		φ D	φ D1	L	H1	H	φ D0	φ D2	
RVY Straight stop valve	RVY100	108	99	390	428	455	208	180	19
	RVY125	133	123	470	500	535	229	200	28
	RVY150	159	149	545	560	605	267	250	38
	RVY200	219	205	650	710	760	333	350	78
	RVY250	273	259	780	870	935	410	400	145
	RVY300	325	305	1065	1070	1155	450	500	288
	RVY350	377	355	1225	1185	1260	505	500	390
	RVY400	426	402	1380	1300	1420	565	500	
RVY450	480	456	1530	1380	1500	650	500		

RVT100-450 Welding angle stop valve

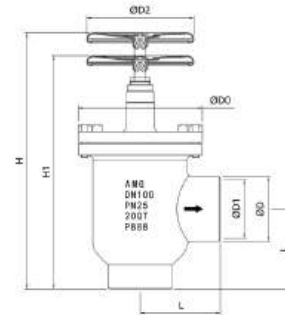

Name	Type	Size(mm)							Weight (Kg)
		φ D	φ D1	L	H1	H	φ D0	φ D2	
RVT Angle stop valve	RVT100	108	99	134	390	430	208	180	16
	RVT125	133	124	155	450	505	229	200	22
	RVT150	159	149	175	500	560	267	250	31
	RVT200	219	205	210	660	750	333	350	68
	RVT250	273	259	250	710	800	410	400	106
	RVT300	325	305	300	885	1000	450	500	205
	RVT350	377	355	355	970	1095	505	500	265
	RVT400	426	402	380	1065	1225	565	500	
RVT450	480	456	390	1100	1265	650	500		

VCY100-150-ZG cast steel straight stop check valve

Technical parameters

Nominal pressure: 4.0MPa Applicable temperature: -45°C ~ +150°C
 Test pressure: 6.0MPa Applicable medium: Ammonia, Freon, CO₂, etc.

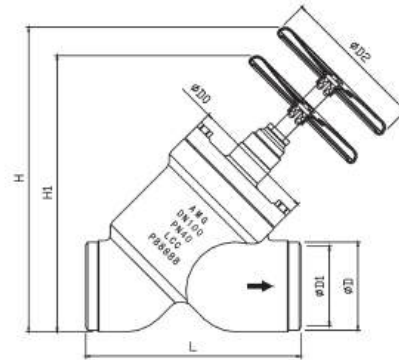

Name	Type	Size(mm)							Weight (Kg)
		φ D	φ D1	L	H1	H	φ D0	φ D2	
VCY-ZG Straight stop check valve	VCY100-ZG	108	99	264	365	405	156	180	19
	VCY125-ZG	133	123	322	445	495	193	200	33
	VCY150-ZG	159	149	370	480	540	219	250	43

VCT100-150-ZG cast steel angle stop check valve

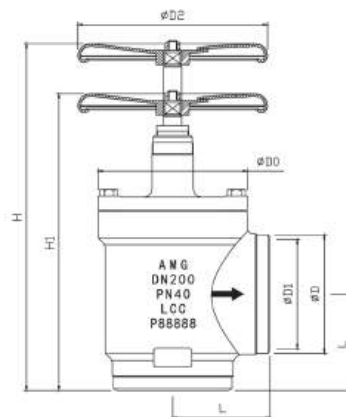

Name	Type	Size(mm)							Weight (Kg)
		φ D	φ D1	L	H1	H	φ D0	φ D2	
VCT-ZG Angle stop check valve	VCT100-ZG	108	99	106	365	425	156	180	18
	VCT125-ZG	133	123	128	430	500	193	200	29
	VCT150-ZG	159	149	145	460	545	219	250	38

Welding stop check valve VCY/VCT

Technical parameters

Nominal pressure: 2.5MPa

Applicable temperature: $-45^{\circ}\text{C} \sim +150^{\circ}\text{C}$

Test pressure: 3.75MPa

Applicable medium: Ammonia, Freon, CO_2 , etc.

VCY100-450 Welding straight stop check valve

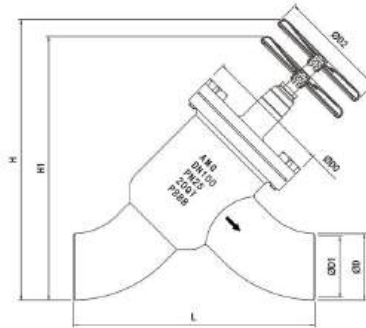

Name	Type	Size(mm)								Weight (Kg)
		ϕD	$\phi D1$	L	H1	H	$\phi D0$	$\phi D2$		
VCY Straight stop check valve	VCY100	108	99	390	435	465	208	180	20	
	VCY125	133	123	470	520	560	229	200	28	
	VCY150	159	149	545	570	605	267	250	38	
	VCY200	219	205	650	770	835	333	350	95	
	VCY250	273	259	780	900	965	410	400	145	
	VCY300	325	305	1065	1070	1155	450	500	288	
	VCY350	377	355	1225	1180	1255	505	500	390	
	VCY400	426	402	1380	1300	1420	565	500		
VCY450	480	456	1530	1380	1500	650	500			

VCT100-450 Welding angle stop check valve

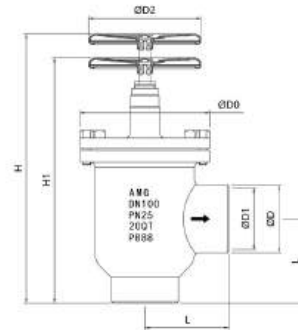

Name	Type	Size(mm)								Weight (Kg)
		ϕD	$\phi D1$	L	H1	H	$\phi D0$	$\phi D2$		
VCT Angle stop check valve	VCT100	108	99	134	400	440	208	180	17	
	VCT125	133	124	155	485	540	229	200	23	
	VCT150	159	149	175	500	552	267	250	32	
	VCT200	219	205	210	690	775	333	350	85	
	VCT250	273	259	250	756	846	410	400	115	
	VCT300	325	305	300	830	930	450	500	230	
	VCT350	377	355	355	970	1080	505	500	285	
	VCT400	426	402	380	1065	1225	565	500		
VCT450	480	456	390	1100	1265	650	500			

RCY/T100-150-ZG cast steel check valve

Technical parameters

Nominal pressure: 4.0MPa Applicable temperature: -45°C ~ +150°C
 Test pressure: 6.0MPa Applicable medium: Ammonia, Freon, CO₂, etc.

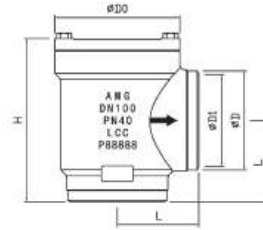
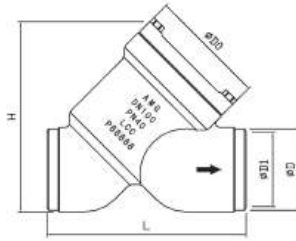

Name	Type	Size(mm)					Weight (Kg)
		φ D	φD1	L	H	φD0	
RCY-ZG Straight check valve	RCY100-ZG	108	99	264	250	156	14
	RCY125-ZG	133	123	322	310	193	26
	RCY150-ZG	159	149	370	355	219	32
RCT-ZG Angle check valve	RCT100-ZG	108	99	106	220	156	12
	RCT125-ZG	133	123	128	270	193	21
	RCT150-ZG	159	149	145	300	219	26

FIA100-150 Y/T -ZG cast steel Filter

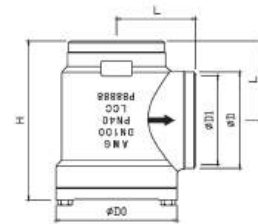
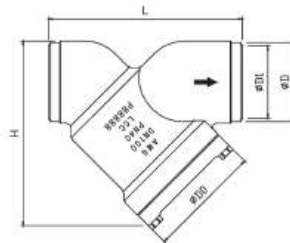

Name	Type	Size(mm)					Weight (Kg)
		φ D	φD1	L	H	φD0	
FIAY-ZG Straight Filter	FIA100Y-ZG	108	99	264	250	156	13
	FIA125Y-ZG	133	123	322	310	193	24
	FIA150Y-ZG	159	149	370	355	219	30
FIAT-ZG Angle Filter	FIA100T-ZG	108	99	106	220	156	11
	FIA125T-ZG	133	123	128	270	193	15
	FIA150T-ZG	159	149	145	300	219	22

RCY/T100-150 Welding check valve

Technical parameters

Nominal pressure: 2.5MPa Applicable temperature: -45°C ~ +150°C
Test pressure: 3.75MPa Applicable medium: Ammonia, Freon, CO₂, etc.

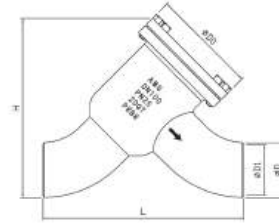

Name	Type	Size(mm)					Weight (Kg)
		φ D	φ D1	L	H	φ D0	
RCY Straight check valve	RCY100	108	99	390	350	208	18
	RCY125	133	123	470	410	229	25
	RCY150	159	149	545	470	267	
RCT Angle check valve	RCT100	108	99	134	265	208	16
	RCT125	133	123	155	305	229	21
	RCT150	159	149	175	345	267	

FIA100-150Y/T Welding filter

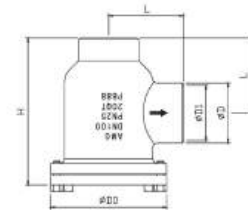
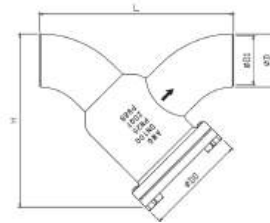

Name	Type	Size(mm)					Weight (Kg)
		φ D	φ D1	L	H	φ D0	
FIAY Straight filter	FIA100Y	108	99	390	350	208	16
	FIA125Y	133	123	470	410	229	22
	FIA150Y	159	149	545	470	267	32
FIAT Angle check valve	FIA100T	108	99	134	265	208	14
	FIA125T	133	123	155	305	229	18
	FIA150T	159	149	175	345	267	27

Technical parameters

Nominal pressure: 2.5MPa Applicable temperature: -45°C ~ +150°C
 Test pressure: 3.75MPa Applicable medium: Ammonia, Freon, CO₂, etc.

TDZ15-125-T Angle Filter

The TDZ filter is available in two connection configurations: angle type and straight type. With a large volume and extensive filtration area, the TDZ filter requires less frequent cleaning. It is suitable for installation before or after pumps, as well as ahead of compressors.

- The filter screens and plates are made of stainless steel, featuring rust-proof characteristics, long service life and easy cleaning.
- The square-hole filter mesh provides large flow area with minimal pressure drop, while the filter element allows convenient installation and maintenance.
- Available stainless steel filter meshes include four specifications: 38 mesh (500µm), 72 mesh (250µm), 100 mesh (150µm) and 150 mesh (100µm).

General guidelines for filter mesh selection:

- For liquid lines - 38 mesh (500µm) before pumps, 100 mesh (150µm) after pumps, 150 mesh (100µm) before electronic expansion valves, 38 mesh (500µm) before general automatic control components, and 72 mesh (250µm) before sensitive automatic control components.
- For suction lines - 72 mesh (250µm) before screw compressors and 100 mesh (150µm) before piston compressors.
- Reference criteria for cleaning or replacing filter screens: ΔP>0.5 bar for liquid lines, ΔP>0.05 bar for suction lines, with the maximum allowable pressure differential of 1 bar for the filters.

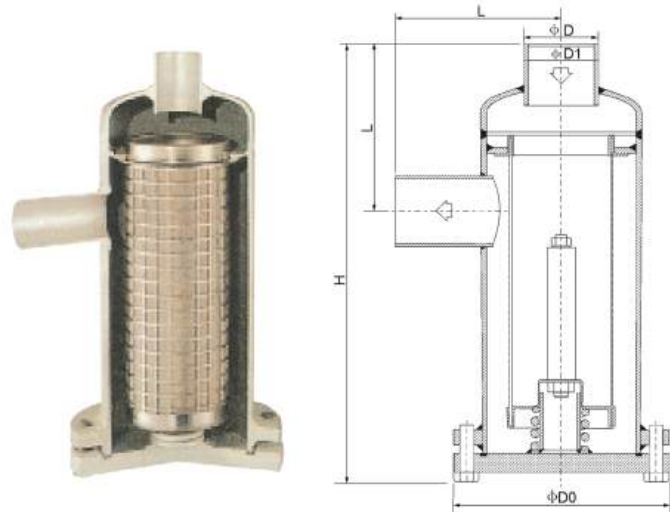

Name	Type	Size(mm)					Weight (Kg)
		φD	φD1	L	H	φD0	
TDZT Angle filter	TDZ15T	21	15	110	270	150	6
	TDZ20T	27	20	110	270	150	6
	TDZ25T	34	25	110	270	150	6
	TDZ32T	42	32	110	270	150	6
	TDZ40T	48	40	140	345	180	11
	TDZ50T	60	50	140	345	180	11
	TDZ65T	76	65	140	345	180	11
	TDZ80T	89	80	140	345	180	11
	TDZ100T	108	99	134	410	208	16
	TDZ125T	133	124	155	470	229	18
TDZ150T	159	149	175	545	267	23	

TDZ15-125-Y straight Filter

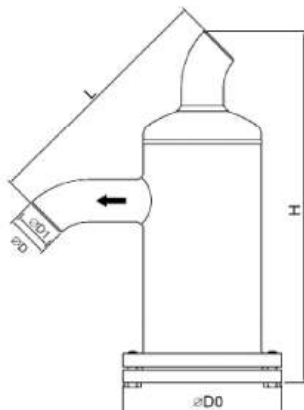

Name	Type	Size(mm)					Weight (Kg)
		φD	φD1	L	H	φD0	
TDZY Straight filter	TDZ15Y	21	15	200	295	150	6
	TDZ20Y	25	20	210	300	150	6
	TDZ25Y	32	25	220	305	150	6
	TDZ32Y	38	32	230	310	150	6
	TDZ40Y	45	40	300	400	180	11
	TDZ50Y	57	50	310	415	180	11
	TDZ65Y	76	65	320	420	180	12
	TDZ80Y	89	80	330	435	180	12
	TDZ100Y	108	99	395	455	208	18
	TDZ125Y	133	123	475	520	229	20
TDZ150Y	159	149	545	610	267	27	

Technical parameters

Nominal pressure: 5.2MPa	Applicable temperature: -45°C ~ +150°C
Test pressure: 7.8MPa	Applicable medium: Ammonia, Freon, CO ₂ , etc.

Characteristics

SVY/SVT stop valves are designed to completely shut off the flow of the working medium moving through the pipeline. Valves are available in angle and straight. The shut-off valves are designed to meet all industrial refrigeration application requirements and are designed to give favourable flow characteristics and are easy to dismantle and repair when necessary. The valve cone is designed to ensure perfect closing and withstand a high system pulsation and vibration, which can be present specifically in the discharge line.

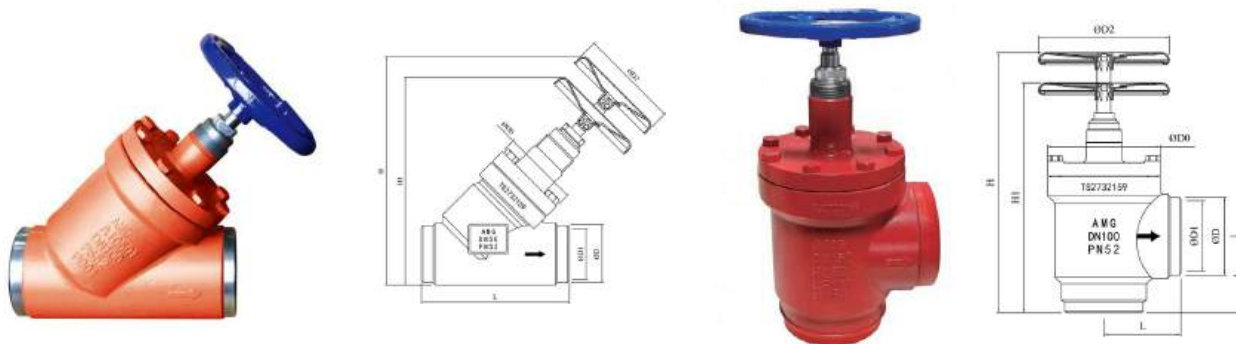

SVY15-150 straight stop valve

SVT15-150 angle stop valve

Name	Type	Size(mm)							Weight (Kg)
		φ D	φ D1	L	H1	H	φ D0	φ D2	
SVY Straight stop valve	SVY15	21	15	120	140	155	60	60	1.6
	SVY20	27	20	120	140	155	60	60	1.6
	SVY25	34	25	120	140	155	60	80	1.7
	SVY32	42	32	120	160	180	60	80	3
	SVY40	48	40	155	185	205	70	80	3
	SVY50	60	50	148	205	225	□77	100	4.1
	SVY65	76	65	176	240	265	□90	120	6.5
	SVY80	89	80	216	285	310	128	160	10
	SVY100	108	99	264	340	375	156	180	17
	SVY125	133	123	322	405	450	193	200	37
SVY150	159	149	370	480	540	219	250	47	

Name	Type	Size(mm)							Weight (Kg)
		φ D	φ D1	L	H1	H	φ D0	φ D2	
SVT Angle stop valve	SVT15	21	15	45	175	195	60	60	1.3
	SVT20	27	20	45	175	195	60	60	1.4
	SVT25	34	25	45	175	195	60	80	1.6
	SVT32	42	32	45	180	205	60	80	2.6
	SVT40	48	40	55	220	250	70	80	2.6
	SVT50	60	50	60	215	240	□77	100	3.2
	SVT65	76	65	70	240	275	□90	120	5.1
	SVT80	89	80	90	280	315	128	160	8.4
	SVT100	108	99	106	325	375	156	180	13
	SVT125	133	123	128	395	460	193	200	27
	SVT150	159	149	145	460	545	219	250	35

Technical parameters

Nominal pressure: 5.2MPa Applicable temperature: -45°C ~ +150°C
 Test pressure: 7.8MPa Applicable medium: Ammonia, Freon, CO₂, etc.

Characteristics

REY/RET control valve are angleway and straightway hand operated regulating valves, which act as normal shut-off valves in closed position. The valves are designed to meet the strict quality requirements on refrigerating installations specified by the international classification societies and are carefully designed to present favourable flow conditions and accurate linear characteristics.

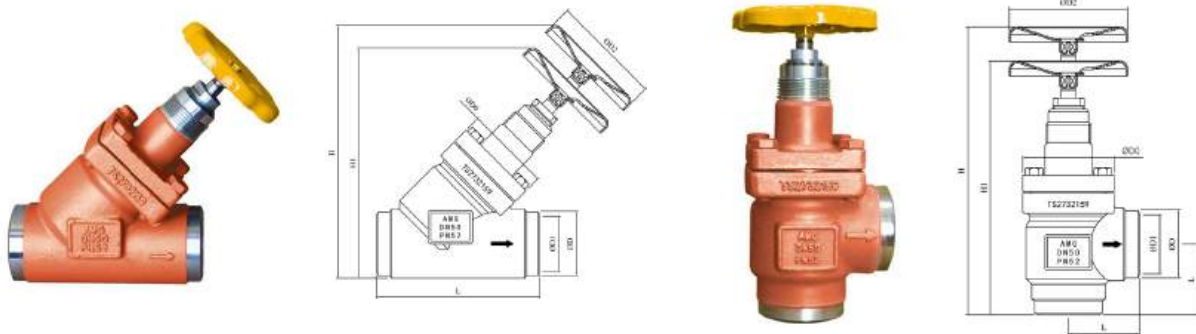

REY15-80 straight control valve

RET15-80 angle control valve

Name	Type	Size(mm)							Weight (Kg)
		φ D	φ D1	L	H1	H	φ D0	φ D2	
REY Straight control valve	REY15	27	20	120	140	155	60	60	1.8
	REY20	34	25	120	140	155	60	80	1.8
	REY25	42	32	120	160	180	60	80	1.9
	REY32	48	40	155	185	205	70	80	3.2
	REY40	60	50	148	205	225	□77	100	3.2
	REY50	76	65	176	240	265	□90	120	4.5
	REY65	89	80	216	285	310	128	160	6.8
REY80	89	80	216	285	310	128	160	10.5	

Name	Type	Size(mm)							Weight (Kg)
		φ D	φ D1	L	H1	H	φ D0	φ D2	
RET Angle control valve	RET15	21	15	45	175	195	60	60	1.5
	RET20	27	20	45	175	195	60	60	1.6
	RET25	34	25	45	175	195	60	80	1.7
	RET32	42	32	45	180	205	60	80	2.8
	RET40	48	40	55	220	250	70	80	2.8
	RET50	60	50	60	215	240	□77	100	3.4
	RET65	76	65	70	240	275	□90	120	5.6
RET80	89	80	90	280	315	128	160	8.8	

Technical parameters

Nominal pressure: 5.2MPa Applicable temperature: -45°C ~ +150°C
 Test pressure: 7.8MPa Applicable medium: Ammonia, Freon, CO₂, etc.

Characteristics

Check valves type CHY/CHT allow the medium to flow in one direction and prevent it from flowing in the opposite direction. The valves are available in angle and straight-flow versions.

The valves are designed to open at very low differential pressures, allow favourable flow conditions and are easy to disassemble for inspection and service.

The valve cone has a built-in flexibility to ensure a precise and tight closing towards the valve seat. A well balanced dampening effect between the piston and the cylinder gives an optimal protection during low loads and against pulsations.

The valves meet all the requirements for industrial refrigeration equipment.

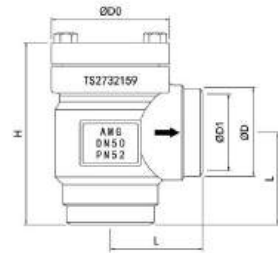
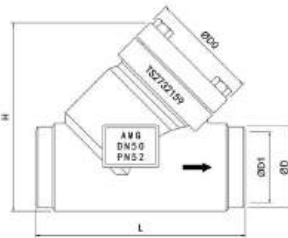

CHY15-150 straight check valve

CHT15-150 angle check valve

Name	Type	Size(mm)					Weight (Kg)
		φ D	φ D1	L	H	φ D0	
CHY Straight check valve	CHY15	21	15	120	90	□60	1.3
	CHY20	27	20	120	90	□60	1.4
	CHY25	34	25	120	90	□60	1.5
	CHY32	42	32	120	95	□60	2.0
	CHY40	48	40	155	125	□70	2.3
	CHY50	60	50	148	135	□77	3.1
	CHY65	76	65	176	160	□90	5.5
	CHY80	89	80	216	205	128	9.8
	CHY100	108	99	264	250	156	19
	CHY125	133	123	322	310	193	25
CHY150	159	149	370	355	219	38	

Name	Type	Size(mm)					Weight (Kg)
		φ D	φ D1	L	H	φ D0	
CHT Angle check valve	CHT15	21	15	45	105	□60	0.9
	CHT20	27	20	45	105	□60	0.9
	CHT25	34	25	45	105	□60	1.1
	CHT32	42	32	45	115	□60	2.2
	CHT40	48	40	55	145	□70	2.2
	CHT50	60	50	60	120	□77	2.6
	CHT65	76	65	70	140	□90	4.1
	CHT80	89	80	90	180	128	7.5
	CHT100	108	99	106	220	156	15
	CHT125	133	123	128	270	193	20
	CHT150	159	149	145	300	219	28

Technical parameters

Nominal pressure: 5.2MPa

 Applicable temperature: $-45^{\circ}\text{C} \sim +150^{\circ}\text{C}$

Test pressure: 7.8MPa

 Applicable medium: Ammonia, Freon, CO_2 , etc.

Characteristics

Stop-check valves type SCY/SCT allow the medium to flow in one direction and prevent it from flowing in the opposite direction. The valves are available in angle and straight-flow versions and have an integrated shut-off function.

The valves are designed to open at very low differential pressures, allow favourable flow conditions and are easy to disassemble for inspection and service.

The valve cone has a built-in flexibility to ensure a precise and tight closing towards the valve seat. A well balanced dampening effect between the piston and the cylinder gives an optimal protection during low loads and against pulsations.

The valves meet all the requirements for industrial refrigeration equipment.

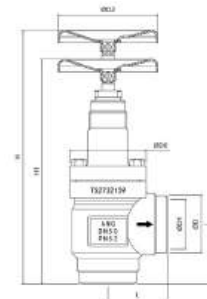
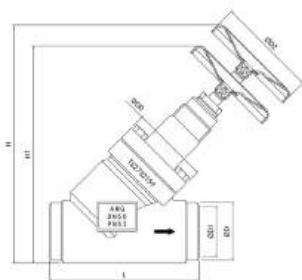

SCY15-150 straight stop check valve

SCT15-150 angle stop check valve

Name	Type	Size(mm)							Weight (Kg)
		ϕ D	ϕ D1	L	H1	H	ϕ D0	ϕ D2	
SCY Straight stop check valve	SCY15	21	15	120	155	170	$\square 60$	60	1.7
	SCY20	27	20	120	155	170	$\square 60$	60	1.7
	SCY25	34	25	120	155	170	$\square 60$	80	1.8
	SCY32	42	32	120	170	185	$\square 60$	80	3.4
	SCY40	48	40	155	205	225	$\square 70$	80	3.4
	SCY50	60	50	148	205	225	$\square 77$	100	4.2
	SCY65	76	65	176	240	265	$\square 90$	120	6.9
	SCY80	89	80	216	310	335	128	160	10
	SCY100	108	99	264	365	405	156	180	19
	SCY125	133	123	322	405	450	193	200	38
SCY150	159	149	370	480	540	219	250	49	

Name	Type	Size(mm)							Weight (Kg)
		ϕ D	ϕ D1	L	H1	H	ϕ D0	ϕ D2	
SCT Angle stop check valve	SCT15	21	15	45	195	215	$\square 60$	60	1.4
	SCT20	27	20	45	195	215	$\square 60$	60	1.4
	SCT25	34	25	45	195	215	$\square 60$	80	1.9
	SCT32	42	32	45	200	225	$\square 60$	80	2.6
	SCT40	48	40	55	245	280	$\square 70$	80	3.0
	SCT50	60	50	60	215	240	$\square 77$	100	3.5
	SCT65	76	65	70	240	275	$\square 90$	120	5.3
	SCT80	89	80	90	320	355	128	160	9.5
	SCT100	108	99	106	365	425	156	180	16
	SCT125	133	123	128	395	460	193	200	31
	SCT150	159	149	145	460	545	219	250	39

Technical parameters

Nominal pressure: 5.2MPa Applicable temperature: -45°C ~ +150°C
 Test pressure: 7.8MPa Applicable medium: Ammonia, Freon, CO₂, etc.

Characteristics

FIY/FIT strainers are used ahead of automatic controls, pumps, compressors etc., for initial plant start-up and where permanent filtration of the refrigerant is required. The strainer reduces the risk of undesirable system breakdowns and reduces wear and tear on plant components. FIY/FIT strainers are a range of angleway and straightway strainers, which are carefully designed to give favourable flow conditions. The design makes the strainer easy to install, and ensures quick Strainer inspection and cleaning.

FIY/FIT strainers are equipped with a screen mesh of stainless steel, available in sizes 100, 150, 250 and 500μ (microns*), (Us 150, 100, 72, 38 mesh*). Mesh is the number of threads per inch. μ (microns) is the distance between two threads (1μ = 1/1000 mm).

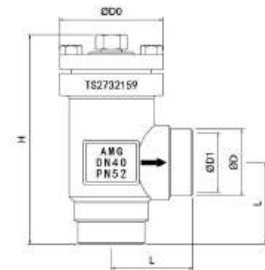
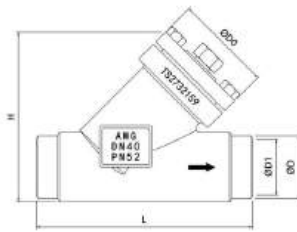

FIY 15-150 straight filter

FIT 15-150 angle filter

Name	Type	Size(mm)					Weight (Kg)
		φ D	φ D1	L	H	φ D0	
FIY Straight filter	FIY15	21	15	120	90	□60	1.2
	FIY20	27	20	120	90	□60	1.2
	FIY25	34	25	120	90	□70	1.4
	FIY32	42	32	120	95	□70	2.0
	FIY40	48	40	155	125	□70	2.2
	FIY50	60	50	148	135	□77	3.1
	FIY65	76	65	176	160	□90	5.0
	FIY80	89	80	216	205	128	8.0
	FIY100	108	99	264	250	156	13
	FIY125	133	123	322	310	193	28
FIY150	159	149	370	355	219	42	

Name	Type	Size(mm)					Weight (Kg)
		φ D	φ D1	L	H	φ D0	
FIT Angle filter	FIT15	21	15	45	110	□60	1.0
	FIT20	27	20	45	110	□60	1.1
	FIT25	34	25	45	110	□70	1.1
	FIT32	42	32	45	115	□70	1.9
	FIT40	48	40	55	140	□70	2.3
	FIT50	60	50	60	130	□77	2.6
	FIT65	76	65	70	150	□90	4.1
	FIT80	89	80	90	190	128	6.2
	FIT100	108	99	106	220	156	11
	FIT125	133	123	128	270	193	18
FIT150	159	149	145	300	219	34	

Technical parameters

Nominal pressure: 4.0MPa

Applicable temperature: -100°C ~ +150°C

Test pressure: 6.0MPa

Applicable medium: Ammonia, Freon, CO₂, etc.

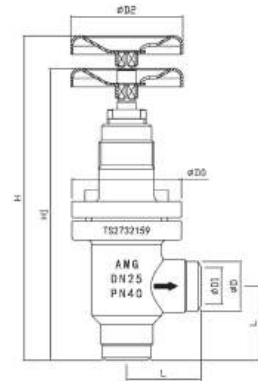
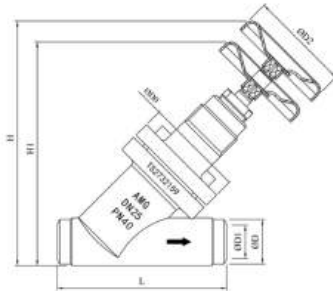

RVY 15-300SS Stainless steel straight stop valve

RVT 15-350SS Stainless steel angle stop valve

Name	Type	Size(mm)							Weight (Kg)
		φ D	φ D1	L	H1	H	φ D0	φ D2	
RVYSS Stainless steel straight stop valve	RVY15SS	21	15	106	137	147	65	60	1.3
	RVY20SS	27	20	106	140	150	65	60	1.4
	RVY25SS	34	25	128	170	186	75	80	2.4
	RVY32SS	42	32	128	174	190	75	80	2.5
	RVY40SS	48	40	165	218	250	95	100	4.3
	RVY50SS	60	50	165	225	258	95	100	4.6
	RVY65SS	76	65	176	240	265	□90	120	8.8
	RVY80SS	89	80	216	290	310	128	160	10
	RVY100SS	108	99	264	340	375	156	180	16
	RVY125SS	133	123	322	445	495	193	200	30
	RVY150SS	159	149	370	480	540	219	250	39
	RVY200SS	219	205	464	615	680	276	350	90
	RVY250SS	273	257	550	715	790	334	400	110
RVY300SS	325	305	620	775	850	384	400	150	

Name	Type	Size(mm)							Weight (Kg)
		φ D	φ D1	L	H1	H	φ D0	φ D2	
RVTSS Stainless steel angle stop valve	RVT15SS	21	15	40	168	183	65	60	1.2
	RVT20SS	27	20	40	168	183	65	60	1.3
	RVT25SS	34	25	51	200	223	75	80	2.1
	RVT32SS	42	32	51	200	223	75	80	2.2
	RVT40SS	48	40	60	246	290	95	100	3.8
	RVT50SS	60	50	64	246	290	95	100	4
	RVT65SS	76	65	70	240	275	□90	120	7.2
	RVT80SS	89	80	90	280	315	128	160	8.3
	RVT100SS	108	99	106	325	375	156	180	14
	RVT125SS	133	123	128	430	500	193	200	27
	RVT150SS	159	149	145	460	545	219	250	35
	RVT200SS	219	205	180	550	645	276	350	73
	RVT250SS	273	257	210	620	725	334	400	100
	RVT300SS	325	305	240	655	760	384	400	140
RVT350SS	377	355	430	720	820	430	500	180	

Technical parameters

Nominal pressure: 4.0MPa

Applicable temperature: -100°C ~ +150°C

Test pressure: 6.0MPa

Applicable medium: Ammonia, Freon, CO₂, etc.

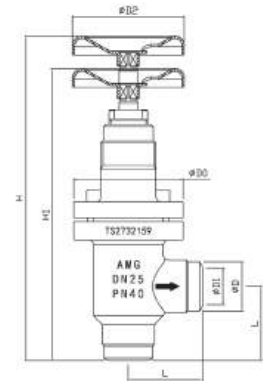
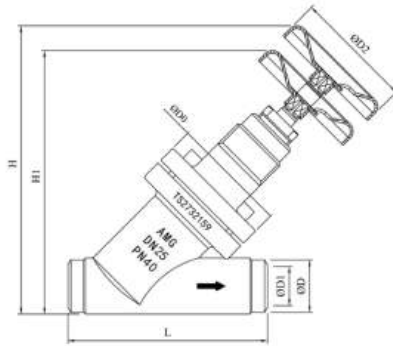

RRY 15-80SS Stainless steel straight control valve

RRT 15-80SS Stainless steel angle control valve

Name	Type	Size(mm)							Weight (Kg)
		φ D	φ D1	L	H1	H	φ D0	φ D2	
RRYSS Stainless steel straight regulating valve	RRY15SS	21	15	106	137	147	65	60	1.4
	RRY20SS	27	20	106	140	150	65	60	1.5
	RRY25SS	34	25	128	170	186	75	80	2.5
	RRY32SS	42	32	128	174	190	75	80	2.5
	RRY40SS	48	40	165	218	250	95	100	4.4
	RRY50SS	60	50	165	225	258	95	100	4.8
	RRY65SS	76	65	176	240	265	□90	120	9.3
RRY80SS	89	80	216	290	310	128	160	11.1	

Name	Type	Size(mm)							Weight (Kg)
		φ D	φ D1	L	H1	H	φ D0	φ D2	
RRTSS Stainless steel angle regulating valve	RRT15SS	21	15	40	168	183	65	60	1.2
	RRT20SS	27	20	40	168	183	65	60	1.3
	RRT25SS	34	25	51	200	223	75	80	2.2
	RRT32SS	42	32	51	200	223	75	80	2.3
	RRT40SS	48	40	60	246	290	95	100	4.1
	RRT50SS	60	50	64	246	290	95	100	4.2
	RRT65SS	76	65	70	240	275	□90	120	7.7
RRT80SS	89	80	90	280	315	128	160	9.1	

Technical parameters

Nominal pressure: 4.0MPa Applicable temperature: -100°C ~ +150°C
 Test pressure: 6.0MPa Applicable medium: Ammonia, Freon, CO₂, etc.

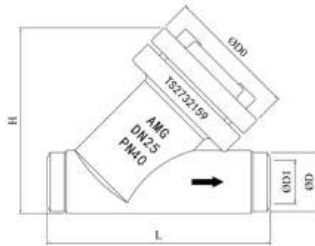

RCY15-150SS Stainless steel straight check valve

RCT 15-150SS Stainless steel angle check valve

Name	Type	Size(mm)					Weight (Kg)
		φ D	φ D1	L	H	φ D0	
RCYSS Stainless steel straight check valve	RCY15SS	21	15	106	87	65	1.1
	RCY20SS	27	20	106	89	65	1.2
	RCY25SS	34	25	128	106	75	1.9
	RCY32SS	42	32	128	110	75	2
	RCY40SS	48	40	165	140	95	3.8
	RCY50SS	60	50	165	146	95	4.2
	RCY65SS	76	65	176	160	□90	7.1
	RCY80SS	89	80	216	205	128	8.4
	RCY100SS	108	99	264	250	156	14
	RCY125SS	133	123	322	310	193	26
RCY150SS	159	149	370	355	219	32	

Name	Type	Size(mm)					Weight (Kg)
		φ D	φ D1	L	H	φ D0	
RCTSS Stainless steel angle check valve	RCT15SS	21	15	40	100	65	1
	RCT20SS	27	20	40	100	65	1.1
	RCT25SS	34	25	51	116	75	1.6
	RCT32SS	42	32	51	116	75	1.7
	RCT40SS	48	40	60	150	95	3.2
	RCT50SS	60	50	64	150	95	3.6
	RCT65SS	76	65	70	140	□90	5.6
	RCT80SS	89	80	90	180	128	6.3
	RCT100SS	108	99	106	210	156	12
	RCT125SS	133	123	128	260	193	21
RCT150SS	159	149	145	295	219	26	

Technical parameters

Nominal pressure: 4.0MPa

Applicable temperature: -100°C ~ +150°C

Test pressure: 6.0MPa

Applicable medium: Ammonia, Freon, CO₂, etc.

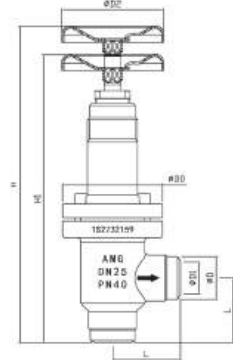
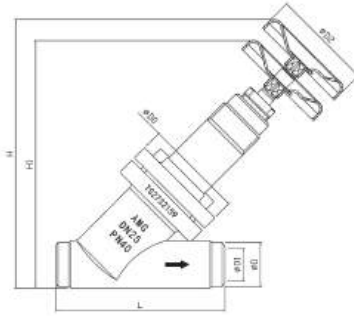

VCY15-150 Stainless steel straight stop check valve

VCT15-150 Stainless steel angle stop check valve

Name	Type	Size(mm)							Weight (Kg)
		φ D	φ D1	L	H1	H	φ D0	φ D2	
VCYSS Stainless steel straight stop check valve	VCY15SS	21	15	106	150	165	65	60	1.5
	VCY20SS	27	20	106	155	170	65	60	1.6
	VCY25SS	34	25	128	190	207	75	80	2.4
	VCY32SS	42	32	128	193	210	75	80	2.8
	VCY40SS	48	40	165	237	264	95	100	4.8
	VCY50SS	60	50	165	243	270	95	100	5
	VCY65SS	76	65	176	240	265	□90	120	8.7
	VCY80SS	89	80	216	310	335	128	160	10
	VCY100SS	108	99	264	365	405	156	180	19
	VCY125SS	133	123	322	445	495	193	200	33
VCY150SS	159	149	370	480	540	219	250	43	

Name	Type	Size(mm)							Weight (Kg)
		φ D	φ D1	L	H1	H	φ D0	φ D2	
VCTSS Stainless steel angle stop check valve	VCT15SS	21	15	40	190	210	65	60	1.3
	VCT20SS	27	20	40	190	210	65	60	1.4
	VCT25SS	34	25	51	227	253	75	80	2.4
	VCT32SS	42	32	51	227	253	75	80	2.5
	VCT40SS	48	40	60	276	313	95	100	4.2
	VCT50SS	60	50	64	276	313	95	100	4.3
	VCT65SS	76	65	70	240	275	□90	120	7.4
	VCT80SS	89	80	90	320	355	128	160	8.2
	VCT100SS	108	99	106	365	425	156	180	18
	VCT125SS	133	123	128	430	500	193	200	29
	VCT150SS	159	149	145	460	545	219	250	38

Technical parameters

Nominal pressure: 4.0MPa Applicable temperature: -100°C ~ +150°C
 Test pressure: 6.0MPa Applicable medium: Ammonia, Freon, CO₂, etc.

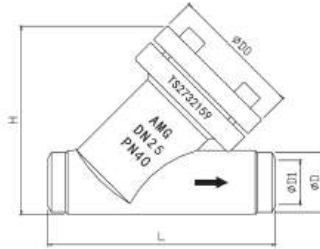

FIA15-150SS-Y Stainless steel straight filter

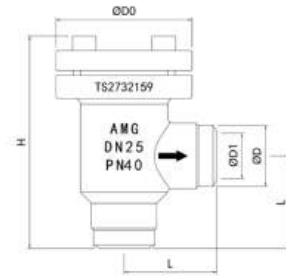

FIA15-150SS-T Stainless steel angle filter

Name	Type	Size(mm)					Weight (Kg)
		φ D	φ D1	L	H	φ D0	
FIAYSS Stainless steel straight filter	FIA15SS-Y	21	15	106	87	65	1.0
	FIA20SS-Y	27	20	106	89	65	1.1
	FIA25SS-Y	34	25	128	106	75	1.5
	FIA32SS-Y	42	32	128	110	75	1.7
	FIA40SS-Y	48	40	165	140	95	3.0
	FIA50SS-Y	60	50	165	146	95	3.3
	FIA65SS-Y	76	65	176	160	□90	5.8
	FIA80SS-Y	89	80	216	205	128	7.1
	FIA100SS-Y	108	99	264	250	156	13
	FIA125SS-Y	133	123	322	310	193	24
	FIA150SS-Y	159	149	370	355	219	30

Name	Type	Size(mm)					Weight (Kg)
		φ D	φ D1	L	H	φ D0	
FIATSS Stainless steel angle filter	FIA15SS-T	21	15	40	92	65	0.9
	FIA20SS-T	27	20	40	92	65	0.9
	FIA25SS-T	34	25	51	110	75	1.2
	FIA32SS-T	42	32	51	110	75	1.4
	FIA40SS-T	48	40	60	138	95	2.4
	FIA50SS-T	60	50	64	138	95	2.7
	FIA65SS-T	76	65	70	150	□90	4.4
	FIA80SS-T	89	80	90	190	128	5.1
	FIA100SS-T	108	99	106	220	156	11
	FIA125SS-T	133	123	128	270	193	15
	FIA150SS-T	159	149	145	300	219	22

ANRVA15-65/RCH25-350 Welding neck flange straight check valve

Technical parameters

Nominal pressure: 4.0MPa

Applicable temperature: -100°C ~ +150°C

Test pressure: 6.0MPa

Applicable medium: Ammonia, Freon, CO₂, etc.

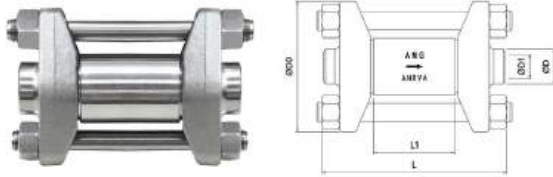

Name	Type	Size(mm)					Weight (Kg)
		φ D	φ D1	L	L1	φ D0	
ANRVA Flange straight check valve	ANRVA15	21	15	115	50	○80	1
	ANRVA20	27	20	115	60	○80	1.1
	ANRVA25	34	25	140	70	□60	1.9
	ANRVA32	42	32	150	75	□70	2.2
	ANRVA40	48	40	170	95	□90	4.1
	ANRVA50	60	50	170	95	□90	4
ANRVA65	76	65	125	225	185	9	

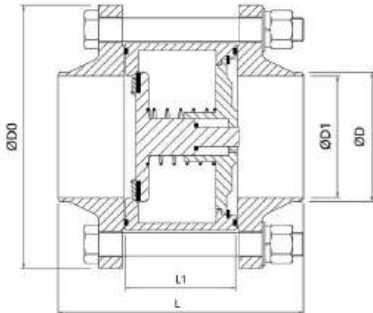

Name	Type	Size(mm)					Weight (Kg)
		φ D	φ D1	L	L1	φ D0	
RCH-F Flange straight check valve	RCH25-F	34	25	150	70	115	4.35
	RCH32-F	42	32	155	70	140	6.3
	RCH40-F	48	40	165	72	150	7.6
	RCH50-F	60	50	175	77	165	9.4
	RCH65-F	76	65	195	90	185	14.3
	RCH80-F	89	80	220	100	200	17.9
	RCH100-F	108	99	245	113	235	25.4
	RCH125-F	133	124	265	123	270	36
	RCH150-F	159	149	285	130	300	46.4
	RCH200-F	219	205	325	160	360	71.6
	RCH250-F	273	259	360	180	425	102.5
	RCH300-F	325	305	380	190	485	
RCH350-F	377	355	425	220	555		



RCH80-400 Screw machine dedicated to brea the check valve

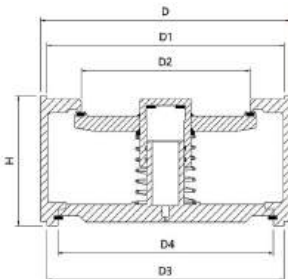

Name	Type	Size(mm)						Weight (Kg)
		φ D	φ D1	φ D2	φ D3	φ D4	H	
RCH Special Inhalation Check Valve for Screw Machine	RCH32	73	65	32	66	47	75	1.5
	RCH40	86	75	42	76	55	80	2
	RCH50	93	87	52	88	65	85	2.3
	RCH65	118	109	65	110	85	97	4.5
	RCH80	138	120	80	121	95	108	5.5
	RCH100	144	129	96	129	110	123	6
	RCH125	165	154	105	155	120	123	9
	RCH150	200	190	135	190	160	130	12
	RCH200	270	259	190	260	229	160	23
	RCH250	348	330	235	331	300	180	33
	RCH300	400	363	290	364	320	190	56
	RCH350	453	421	338	422	380	220	73
RCH400	505	474	370	477	430	260	99	



Technical parameters

Nominal pressure: 5.2MPa

Applicable temperature: $-45^{\circ}\text{C} \sim +150^{\circ}\text{C}$

Test pressure: 7.8MPa

Applicable medium: Ammonia, Freon, CO_2 , etc.

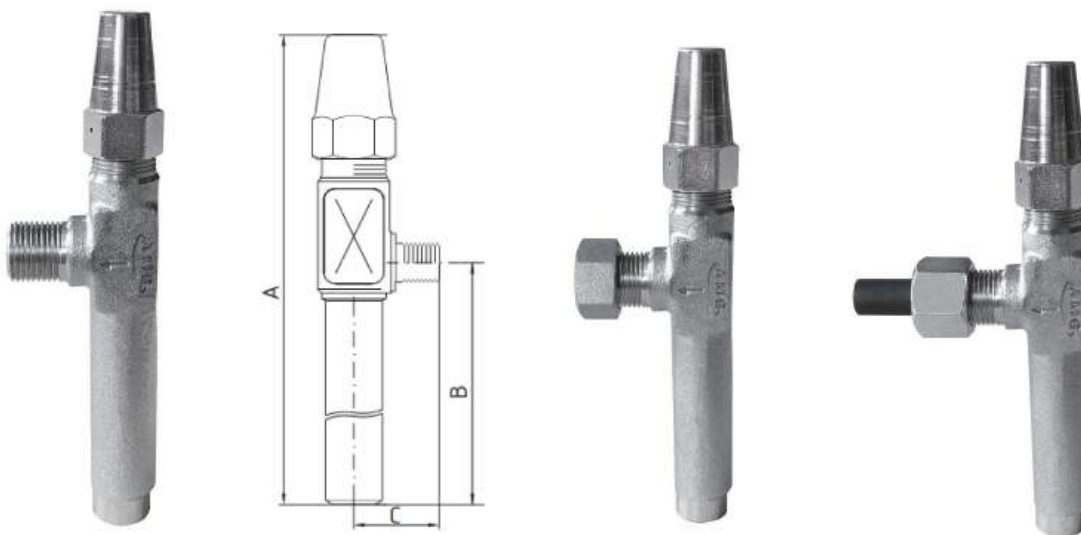

Characteristics

RVT10-L100 valves are designed to meet all industrial refrigeration application requirements. Designed as service valves they provide favourable flow characteristics.

Valves can be of two modifications:

- RVT10-L100-S with a short fitting
- RVT10-L100-L with an extended fitting

Name	Type	Design Type	In	Out	Size(mm)			Weight (Kg)
					A	B	C	
RVT10-L100 Small size stop valve	RVT10-L100 G1/2"-W1/2"	Angle	G1/2"	W1/2	182	100	34	1.2
	RVT10-L100-S G1/2"-W1/2"	Angle	G1/2"	W1/2	182	100	34	1.2
	RVT10-L100-L G1/2"-W1/2"	Angle	G1/2"	W1/2	182	100	34	1.2

Small size stop valve

RV6-10 Small size stop valves with various thread connections

Technical parameters

Nominal pressure: 5.2MPa

Applicable temperature: $-45^{\circ}\text{C} \sim +150^{\circ}\text{C}$

Test pressure: 7.8MPa

Applicable medium: Ammonia, Freon, CO_2 , etc.

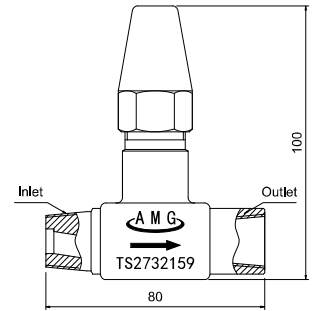
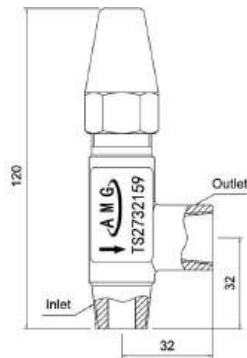
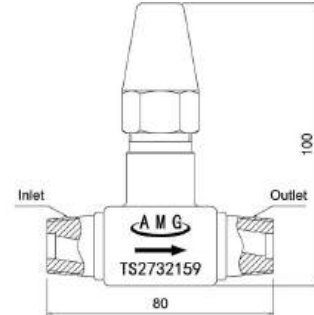
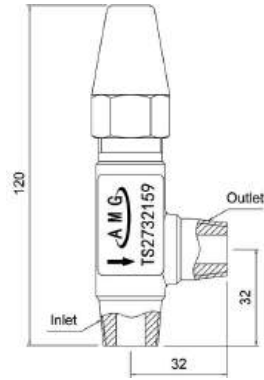

(NO.AMG)	Inlet(Vertical interface)	Outlet(Horizontal interface)	Remarks:Angle valves
AMG01	1/4"	1/4"	Threads are male threads R
AMG02	3/8"	3/8"	
AMG03	1/2"	1/2"	
AMG04	1/4"	1/4"	Threads are male threads MPT
AMG05	3/8"	3/8"	
AMG06	1/2"	1/2"	
AMG07	1/4"	1/4"	Vertical port connection is male threaded R Horizontal port connection is female threaded RC
AMG08	3/8"	3/8"	
AMG09	1/2"	1/2"	
AMG10	1/4"	1/4"	Vertical port connection is male threaded MPT Horizontal port connection is female threaded FPT
AMG11	3/8"	3/8"	
AMG12	1/2"	1/2"	

(NO.AMG)	Inlet(Vertical interface)	Outlet(Horizontal interface)	Remarks:Straight valves
AMG13	1/4"	1/4"	Threads are male threads R
AMG14	3/8"	3/8"	
AMG15	1/2"	1/2"	
AMG16	1/4"	1/4"	Threads are male threads MPT
AMG17	3/8"	3/8"	
AMG18	1/2"	1/2"	
AMG19	1/4"	1/4"	Vertical port connection is male threaded R Horizontal port connection is female threaded RC
AMG20	3/8"	3/8"	
AMG21	1/2"	1/2"	
AMG22	1/4"	1/4"	Vertical port connection is male threaded MPT Horizontal port connection is female threaded FPT
AMG23	3/8"	3/8"	
AMG24	1/2"	1/2"	

RVY6-10-D Forged steel straight stop valve



Technical parameters

Nominal pressure: 5.2MPa

Applicable temperature: -45°C ~ +150°C

Test pressure: 7.8MPa

Applicable medium: Ammonia, Freon, CO₂, etc.

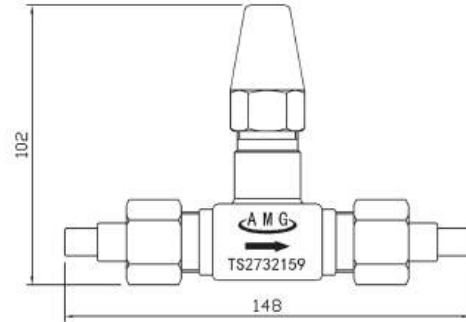

RVT6-10-D Forged steel angle stop valve

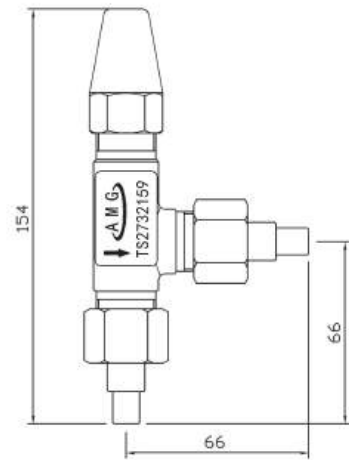

TH4 Three-way stop valve

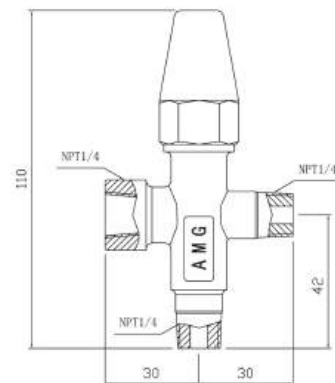

Technical parameters

RVY6-10 Straight-through pressure gauge valve

Nominal pressure: 5.2MPa

Applicable temperature: $-45^{\circ}\text{C} \sim +150^{\circ}\text{C}$

Test pressure: 7.8MPa

Applicable medium: Ammonia, Freon, CO_2 , etc.

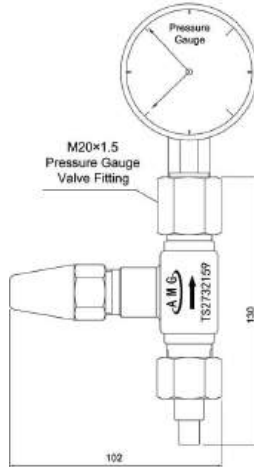

RVT6-10 Right-angle pressure gauge valve

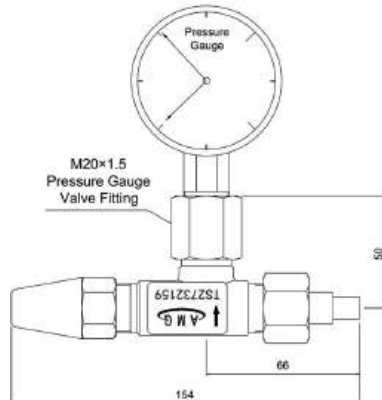
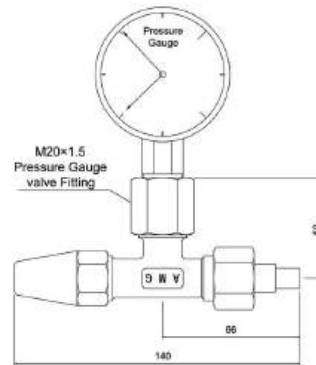

Technical parameters

Nominal pressure: 4.0MPa Applicable temperature: -50°C ~ +120°C
 Test pressure: 6.0MPa Applicable medium: Ammonia, Freon, CO₂, etc.



Characteristics

- LLG-A are sight glasses in ductile steel which meets the strictest requirements on industrial and marine refrigeration installations.
- The range of sight glasses is based on 3 basic sight glasses: LLG 185, LLG 335 and LLG 740. The other standard lengths are combined by using variations of basic glass lengths. LLG 590, LLG 995, LLG 1145 and LLG 1550 are joined together by 2 basic LLG's by means of a connector. The connector holds the two basic glasses together by means of screws and guiding pins, which ensures a rigid construction.
- LLG produce sufficient flow areas to secure the highest possible degree of synchronous operation, and have a specially hardened reflection glass for quick reading. The front and the base frame are mounted together from the front with countersunk allen screws. This ensures easy insulation on site as well as easy inspection and service, if any.
- All sight glasses are equipped as standard with a built-in safety system (non return device). If a glass is damaged, the pressure of the refrigerant will activate the safety system and refrigerant loss will be limited to an absolute minimum.

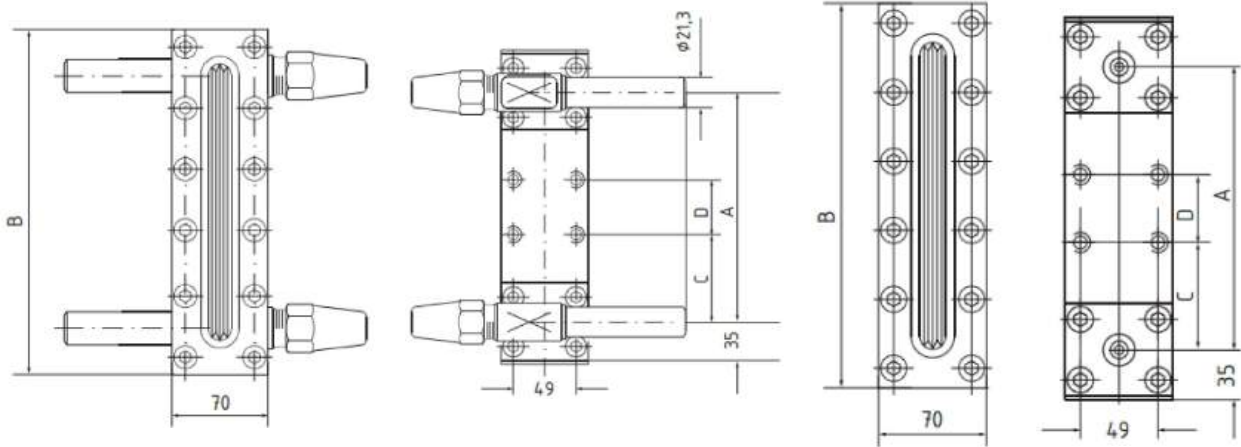

Type	Size(mm)			
	A	B	C	D
LLG-A 185	185	255	69	48
LLG-A 335	335	405	63	42
LLG-A 590	590	660	69+63	48+42
LLG-A 740	740	810	63	42
LLG-A 995	995	1065	69+63	48+42
LLG-A 1145	1145	1215	63	42
LLG-A 1550	1550	1620	63	42

Technical parameters

Nominal pressure: 5.2MPa Applicable temperature: -60°C ~ +120°C
 Test pressure: 7.8MPa Applicable medium: Ammonia, Freon, CO₂, etc.

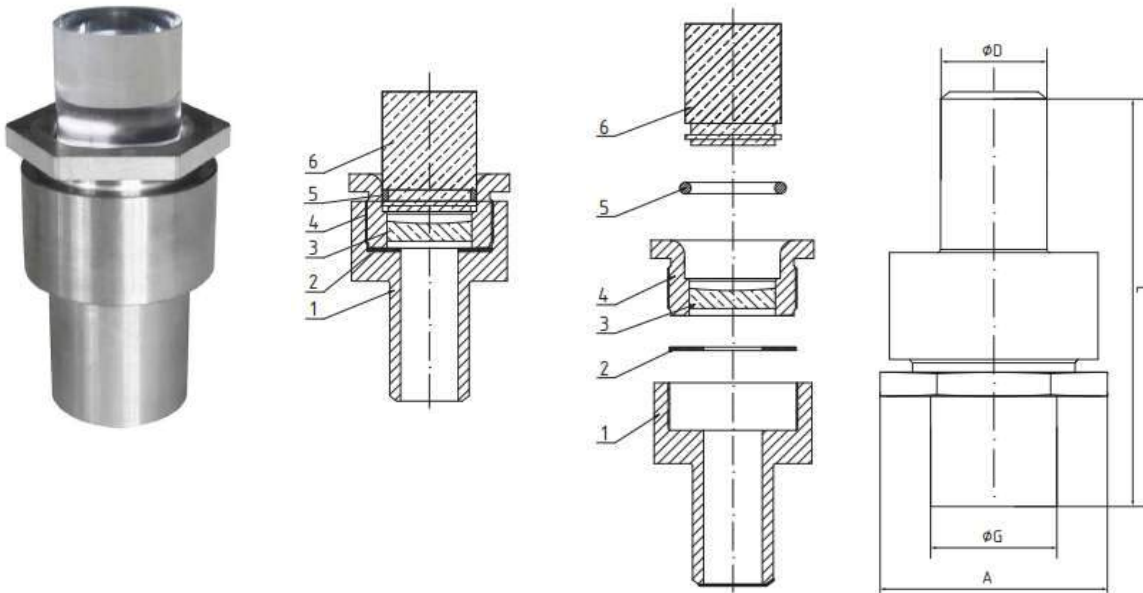

Characteristics

- SG-A sight glasses are designed to meet all industrial refrigeration application requirements. SG-R type sight glasses are designed for visual inspection of the refrigerant status in the system, as well as for indicating the liquid level in the receiver or the oil level in the compressor crankcase.
- The sight glasses are a completely disassembled product, ensuring high reparability.

Type	Size(mm)			
	φ D	φ G	A	L
SG-A	33.7	40	72	131.6

Piping Connection for Plate Quick-Freezer with Hot Gas Defrost in a Pump-Circulation Scheme

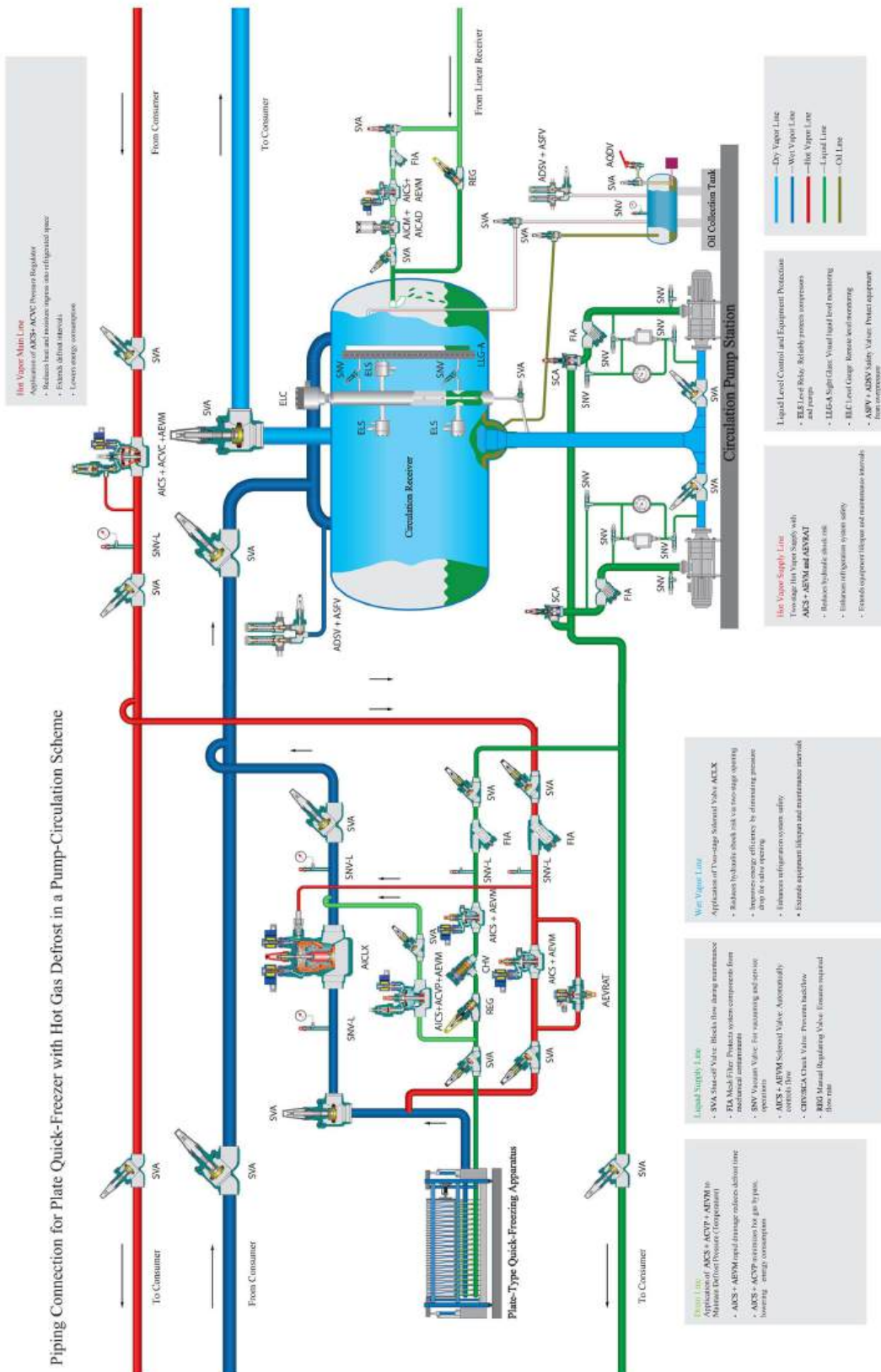

Hot Vapor Main Line
Application of ACS+ACVC Pressure Regulator
 • Reduces heat and moisture ingress into refrigerated space
 • Extends shelf life
 • Lowers energy consumption

Hot Vapor Supply Line
Preventing hot vapor supply with ACS+AEVM and AEVDT
 • Reduces hot liquid check risk
 • Enhances refrigeration system safety
 • Extends equipment lifespan and maintenance intervals
 • ELC Level Control: Remote level monitoring from compressor

Wet Vapor Line
Application of Two-stage Solenoid Valve ACCK
 • Reduces hot liquid check risk via two-stage solenoid valve for the other opening
 • Enhances refrigeration system safety
 • Extends equipment lifespan and maintenance intervals

Liquid Supply Line
 • SVA Checkoff Valve: Blocks flow during maintenance
 • FIA Check Filter: Protects system components from mechanical contaminants
 • SVA Vacuum Valve: For vacuuming and/or oil recovery
 • ACS+AEVM Solenoid Valve: Automatically controls flow
 • CSPECCA Check Valve: Prevents backflow
 • RRS Manual Regulating Valve: Ensures required flow rate

Oil Collection Tank
 • ELS Level Bubbler: Reliably protects compressors and pumps
 • ELC Level Control: Remote level monitoring from compressor
 • ACS+AEVM Solenoid Valve: Automatically controls flow
 • CSPECCA Check Valve: Prevents backflow
 • RRS Manual Regulating Valve: Ensures required flow rate

Plate-Type Quick-Freezing Apparatus
 • ACS+ACVP Pressure Regulator
 • ACS+AEVM Solenoid Valve
 • ACS+AEVM Solenoid Valve
 • ACS+AEVM Solenoid Valve
 • ACS+AEVM Solenoid Valve

Legend
 • Hot Vapor Main Line
 • Hot Vapor Supply Line
 • Wet Vapor Line
 • Liquid Line
 • Oil Line







